

INSTALLATION INSTRUCTIONS AND OWNER'S MANUAL

BLUE BAY

LOG SET MODELS

LS38DF-1

LS48DF-1

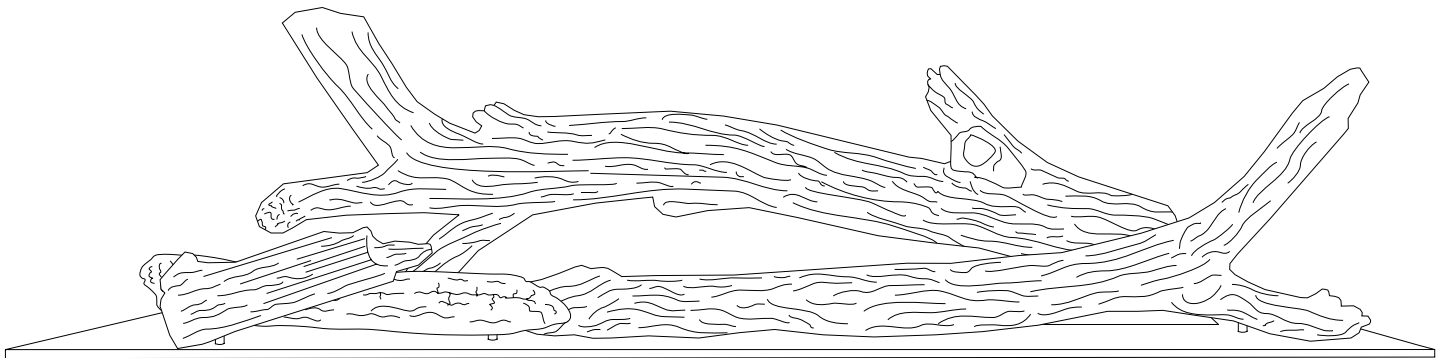

INSTALLER: Leave this manual with the appliance.
CONSUMER: Retain this manual for future reference.

WARNINGS

If the information in this manual is not followed exactly, a fire or explosion may result causing property damage, personal injury or loss of life.

- Do not store or use gasoline or other flammable vapors and liquids in the vicinity of this or any other appliance.

WHAT TO DO IF YOU SMELL GAS

- Do not try to light any appliance.
- Do not touch any electrical switch; do not use any phone in your building.
- Immediately call your gas supplier from neighbor's phone. Follow the gas supplier's instructions.
- If you cannot reach your gas supplier, call the fire department.
- Installation and service must be performed by a qualified installer, service agency or the gas supplier.



We suggest that our gas hearth products be installed and serviced by professionals who are certified in the U.S. by the National Fireplace Institute® (NFI) as NFI Gas Specialists.

Log sets comply with ANSI Z21.11.2 Unvented Heaters and also comply with ANSI Z21.60 Decorative Vented Appliances for Solid Fuel Burning Fireplaces. State or local codes may only allow operation of log sets in a vented configuration. Check your state or local codes.

WARNING: If not installed, operated and maintained in accordance with the manufacturer's instructions, this product could expose you to substances in fuel or from fuel combustion which can cause death or serious illness.

IMPORTANT INSTALLATION GUIDELINES

Proper Log Placement

Log placement is critical to proper burner performance. Logs must be correctly positioned onto the burner. The photos in this manual show the proper pinned position for logs on this set. Owners need to be shown proper log placement and instructed not to move the logs.

Logs must fit firmly onto the burner when positioned as shown in the photos. Misformed logs or logs with sloppy pin holes must be replaced.

Proper Primary Airflow into Burner

For proper burner operation and flame appearance, the flow of primary air into the venturi tube, located under the burner, must not be reduced. This flow of air is reduced if dirt, lint or other obstructions build-up around or inside the venturi. Any obstruction in the venturi tube area must be removed. The flow of air into the venturi is also reduced if the gas orifice isn't centered in the venturi inlet and/or is not aligned with the venturi. Any misalignment of the burner orifice may be corrected by bending the shutter cap holding the orifice to the inlet of the venturi tube.

Ceiling Fans, Portable Fans or Logs Installed Near Cold Air Returns

Ceiling fans or oscillating floor type fans need to be monitored during the operation of vent-free logs. If the air blows directly into the flame causing it to impinge on the log set, or firebox, it should be turned off or redirected. Ceiling fans could be reversed to possibly eliminate flame impingement, and the floor fan could be redirected. Upon installation, be aware of any cold air returns or vents in the proximity of the log set. Any draft created around a vent-free log set can cause the flame to impinge on the log and create a sooting situation.

WARNING: Do not allow fans to blow directly into the fireplace. Avoid any drafts that alter burner flame patterns.

WARNING: Do not use a blower insert, heat exchanger insert or other accessory not approved for use with this heater.

Candles

Avoid the use of scented or decorative candles while the log set is in operation. Candles produce a residue in the air that creates a soot like substance. Burning candles while the log set is operating magnifies the problem. It should be noted that candles, in general, produce soot. The amount of time burned and the quantity of candles burned will determine the amount of soot produced and deposited.

Make Owners Aware of Proper Log Set Operation

Properly installed and properly maintained log sets do not deposit soot on the logs. If users see soot appear on a log, call for service. Do not continue to operate the log set.

GENERAL INFORMATION

Qualified Installing Agency

Installation and replacement of gas piping, gas utilization equipment or accessories and repair and servicing of equipment shall be performed only by a qualified agency. The term "qualified agency" means any individual, firm, corporation, or company that either in person or through a representative is engaged in and is responsible for (a) the installation, testing, or replacement of gas piping or (b) the connection, installation, testing, repair, or servicing of equipment; that is experienced in such work; that is familiar with all precautions required, and that has complied with all the requirements of the authority having jurisdiction.





The installation must conform with local codes or, in the absence of local codes, with the *National Fuel Gas Code, ANSI Z223.1/NFPA54*.*

*Available from the American National Standards Institute, Inc. 11 West 42nd St., New York, N.Y. 10018.

State of Massachusetts: The installation must be made by a licensed plumber or gas fitter in the Commonwealth of Massachusetts.

Sellers of unvented propane or natural gas-fired supplemental room heaters shall provide to each purchaser a copy of 527 CMR 30 upon sale of the unit.

LOG IDENTIFICATION

DESCRIPTION	PART NUMBER		LOG IMAGE
	LS38DF	LS48DF	
REAR LOG	30901	32823	
RIGHT FRONT LOG	30904	30904	
LEFT FRONT LOG	30902	32824	
LEFT BRANCH	30903	30903	

Before you begin: Do not handle these logs with your bare hands! Always wear gloves to prevent skin irritation. After handling logs or removing the glass and removing the gloves, wash your hands gently with soap and water.

All Logs

Properly positioning the logs is critical to the safe and clean operation of this heater. Sooting and other problems may result if the logs are not properly and firmly positioned in the appliance.

⚠ WARNING

Failure to position the parts in accordance with the diagrams and instructions below or failure to use only parts specifically approved for use with this heater may result in property damage or personal injury.

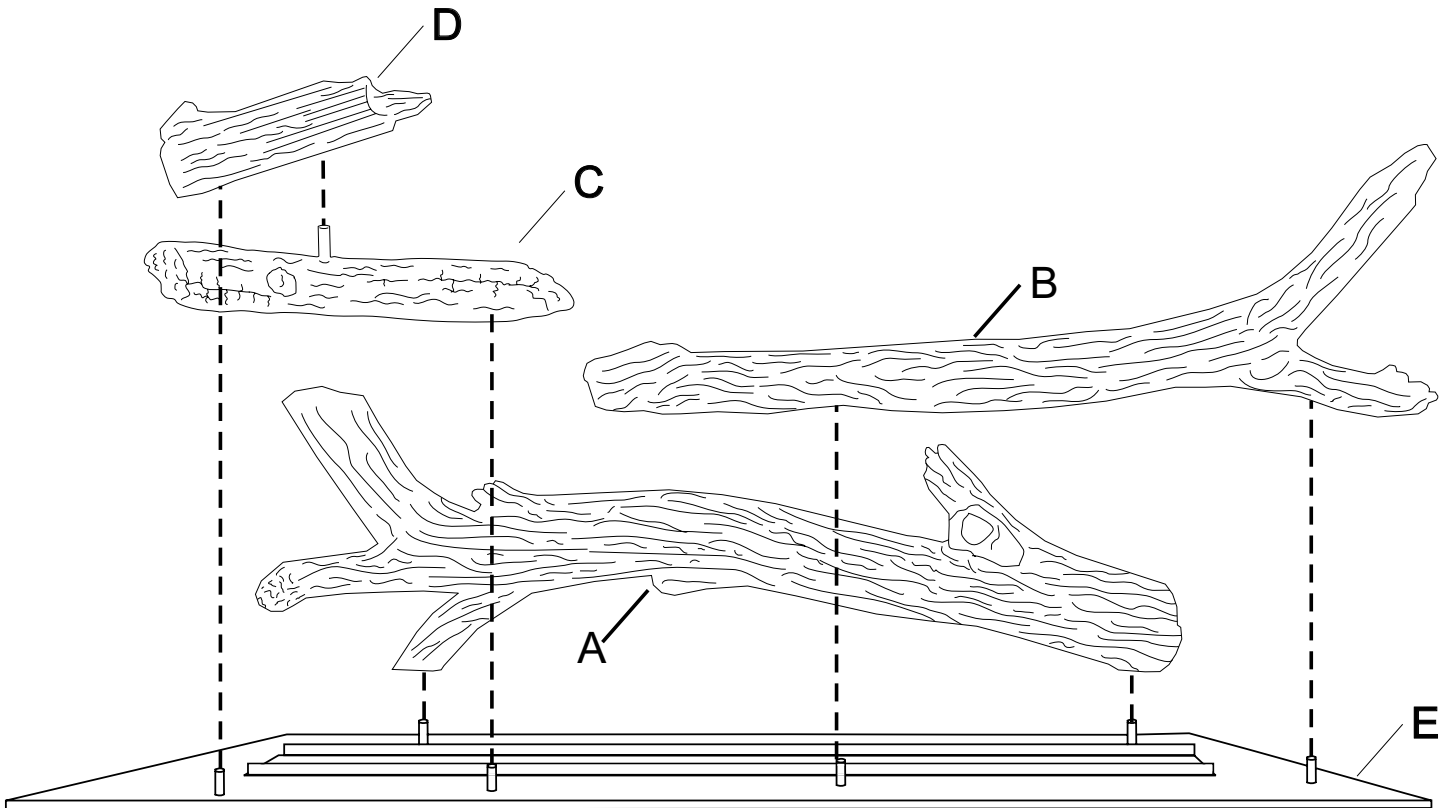

Index Letter	Description	Part Number	
		LS38DF	LS48DF
A	Rear Log	30901	32823
B	Right Front Log	30904	30904
C	Left Front Log	30902	32824
D	Left Branch	30903	30903
E	Log Plate	30437	32821

INSTALLATION

1. Remove glass front from fireplace by lifting the glass front up, sliding it to the right, and then carefully angling left side out of the slots. See Figures 1 - 4.

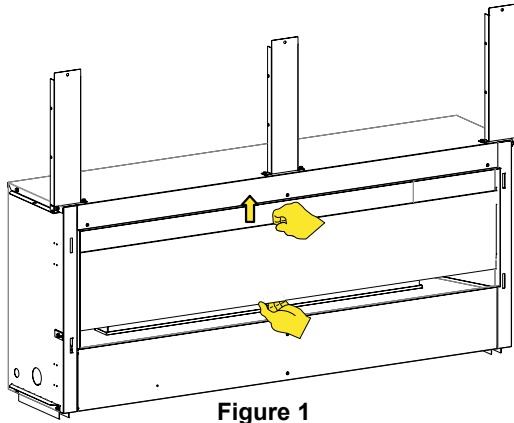

Figure 1

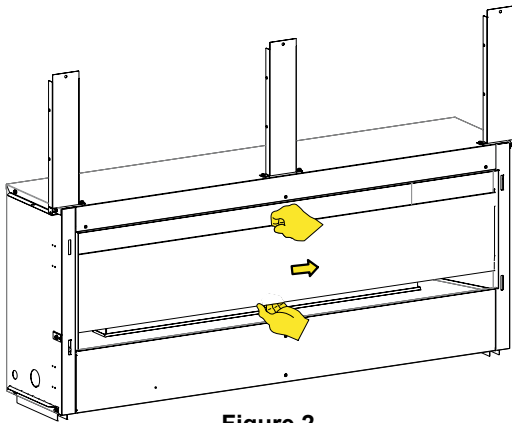

Figure 2

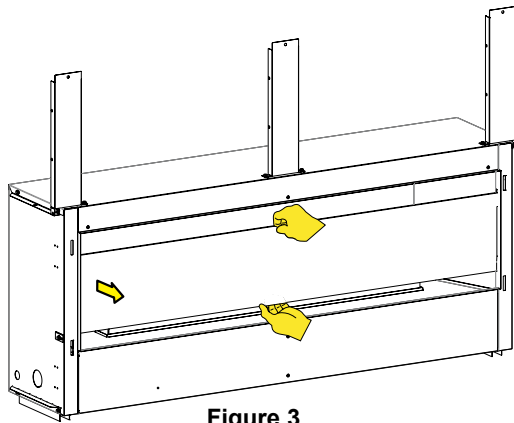

Figure 3

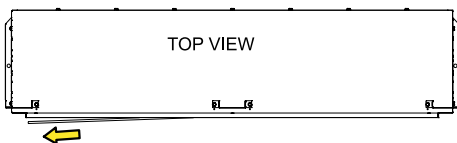
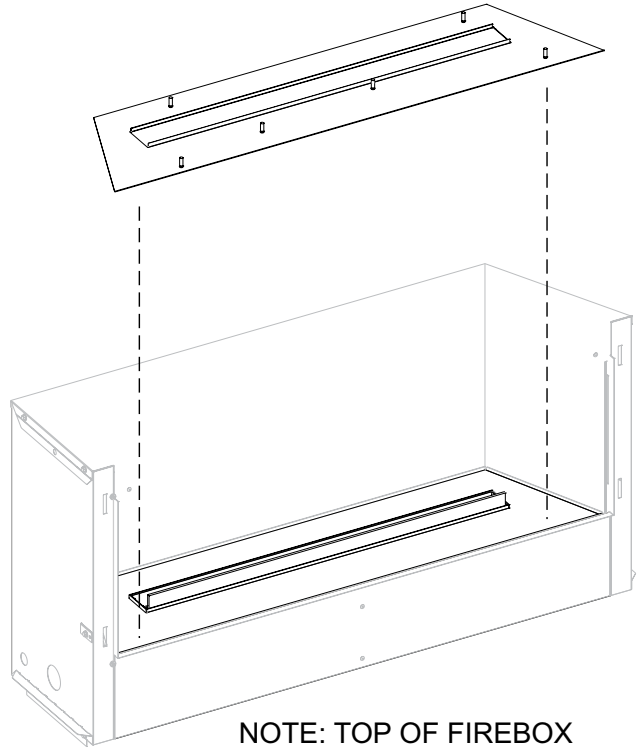

Figure 4

2. Install locator plate over the burner cover assembly.



**NOTE: TOP OF FIREBOX
REMOVED FOR CLARITY.**

Figure 5

3. Place Rear Log onto the rear two pins on the locator plate.

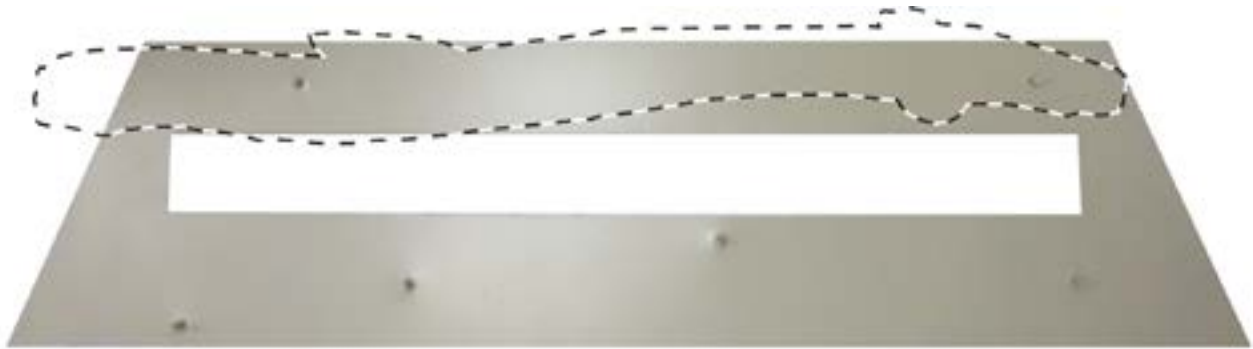

Top View

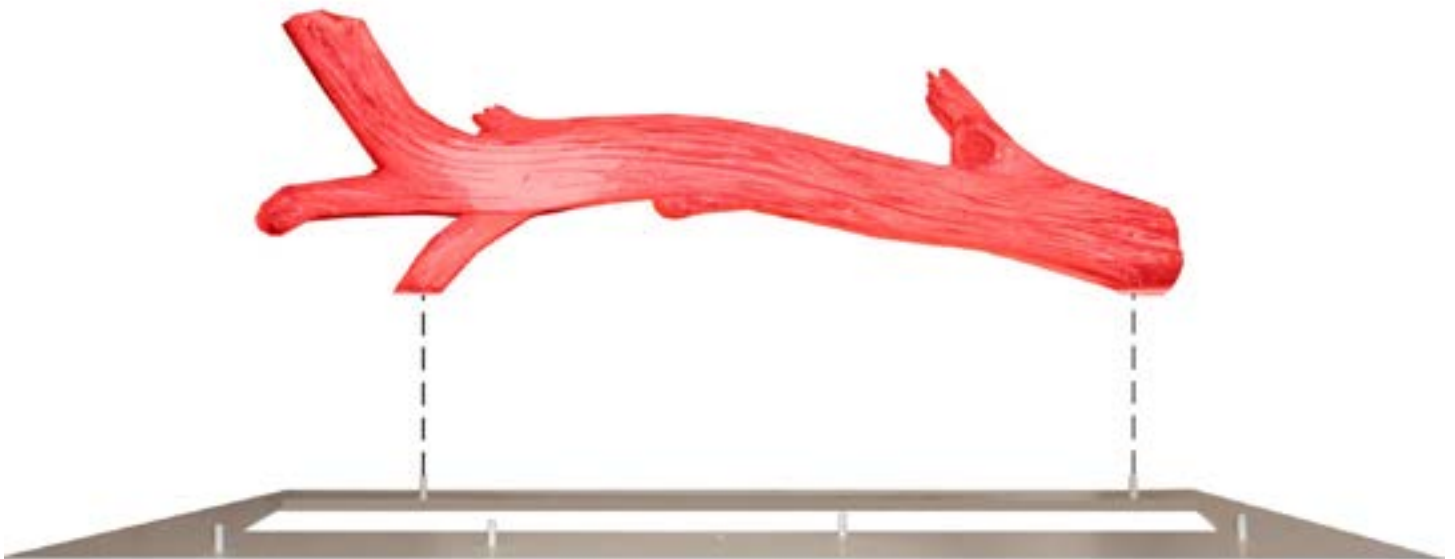

Front View

4. Place Right Front Log onto the two front right pins on the locator plate.

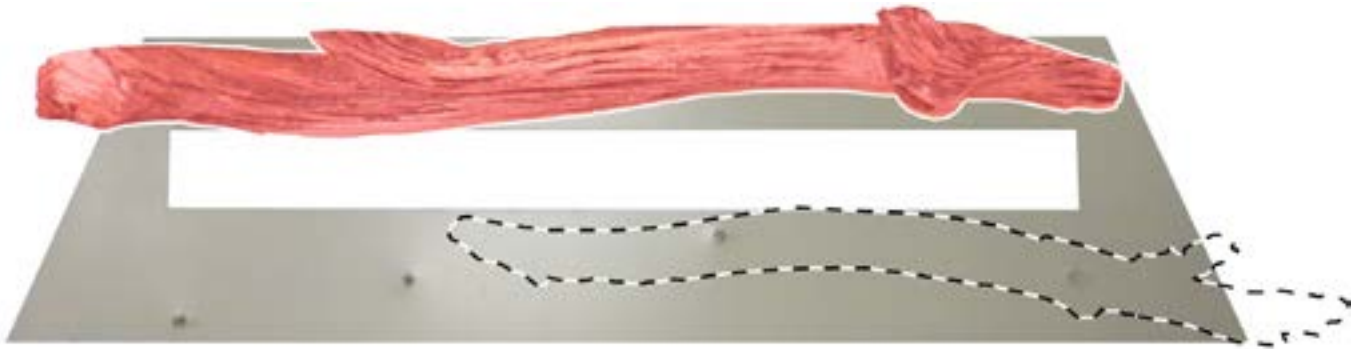

Top View

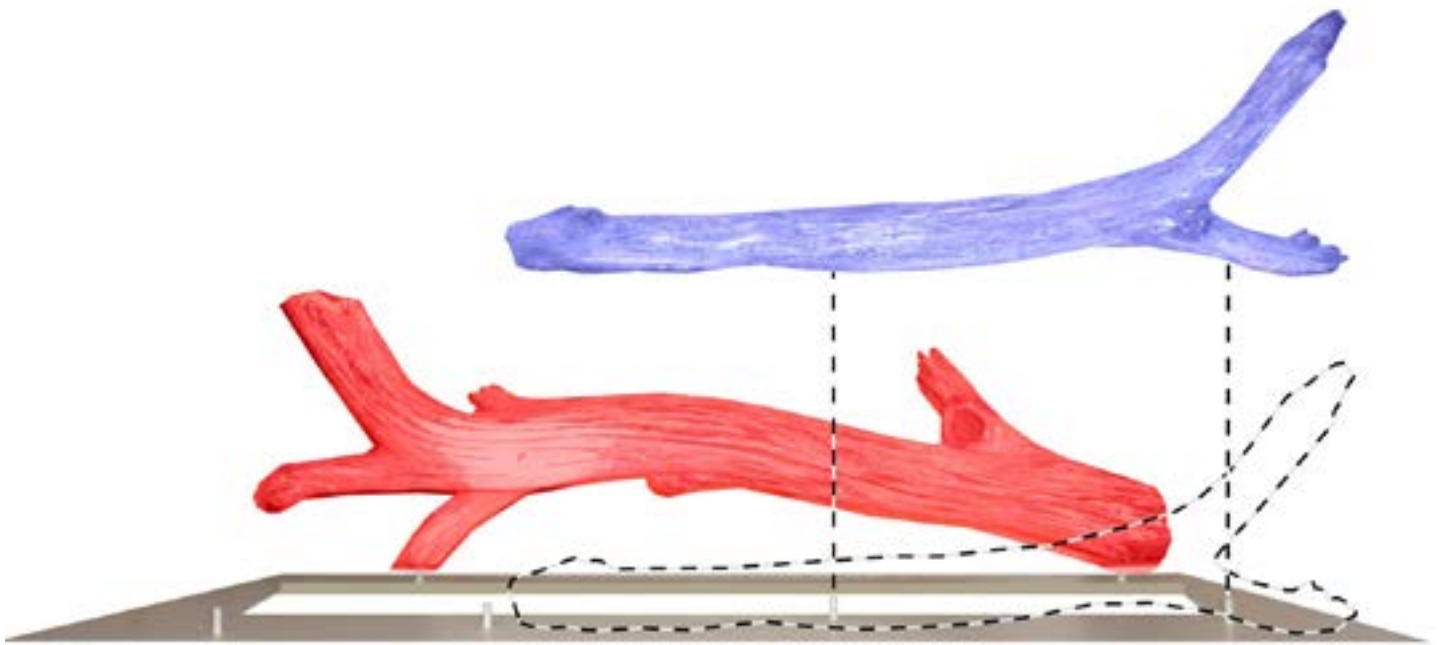

Front View

5. Place Left Front Log onto the middle left front pin on the locator plate. The left end of the log should angle up and will rest against the glass.

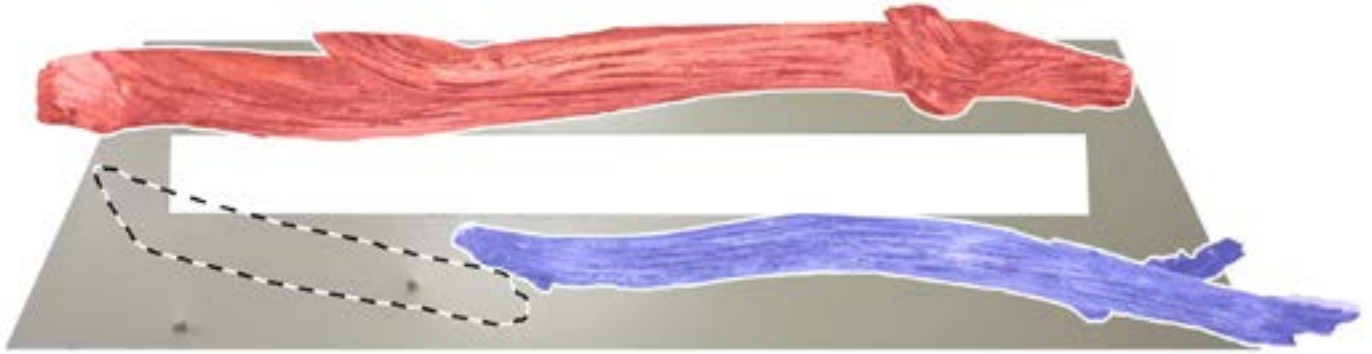

Top View

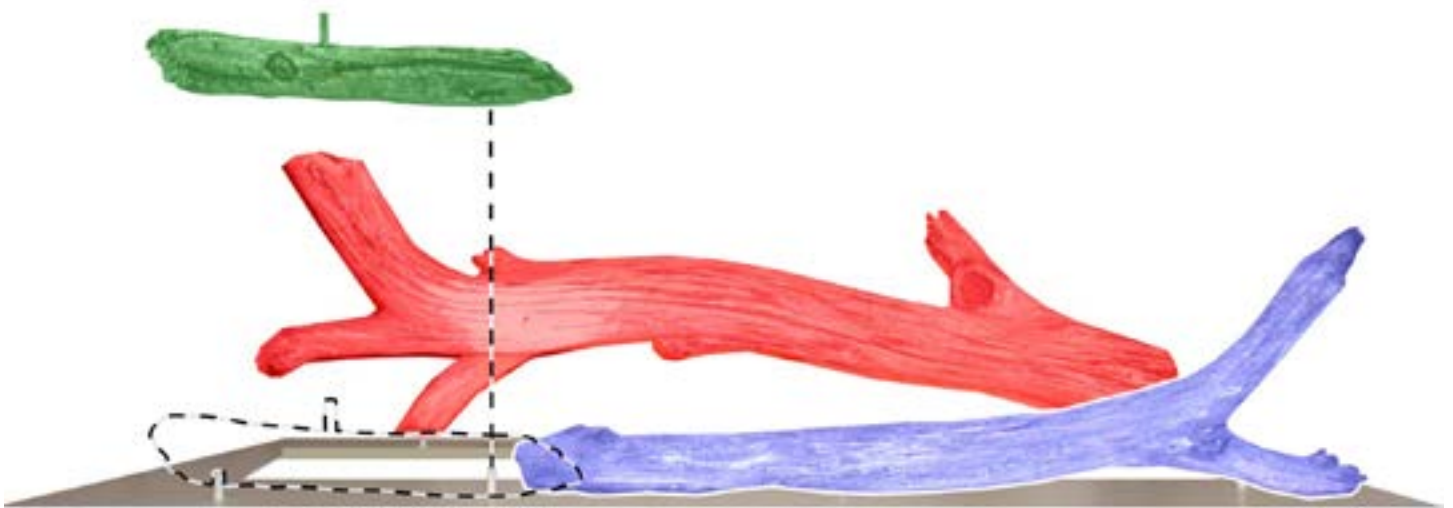

Front View

6. Place the Left Branch on the left pin on the locator plate and the pin on the top of the Left Front Log.

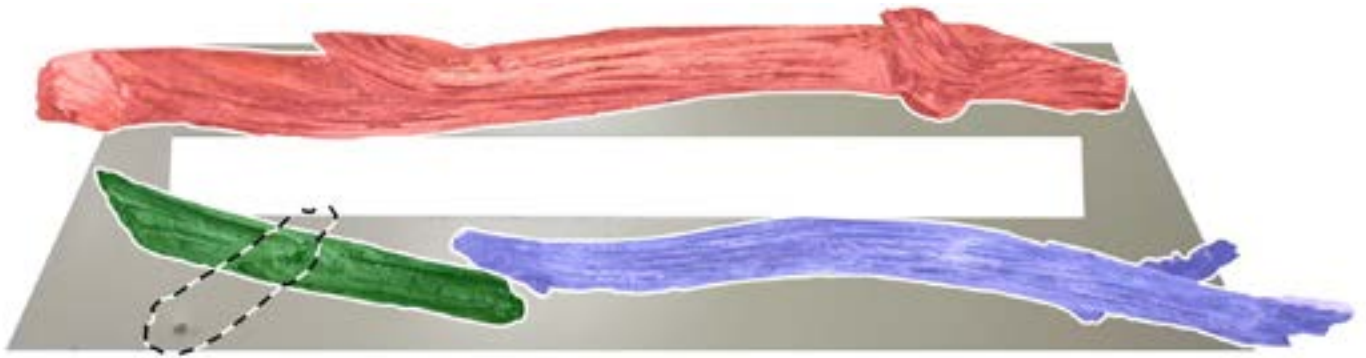

Top View

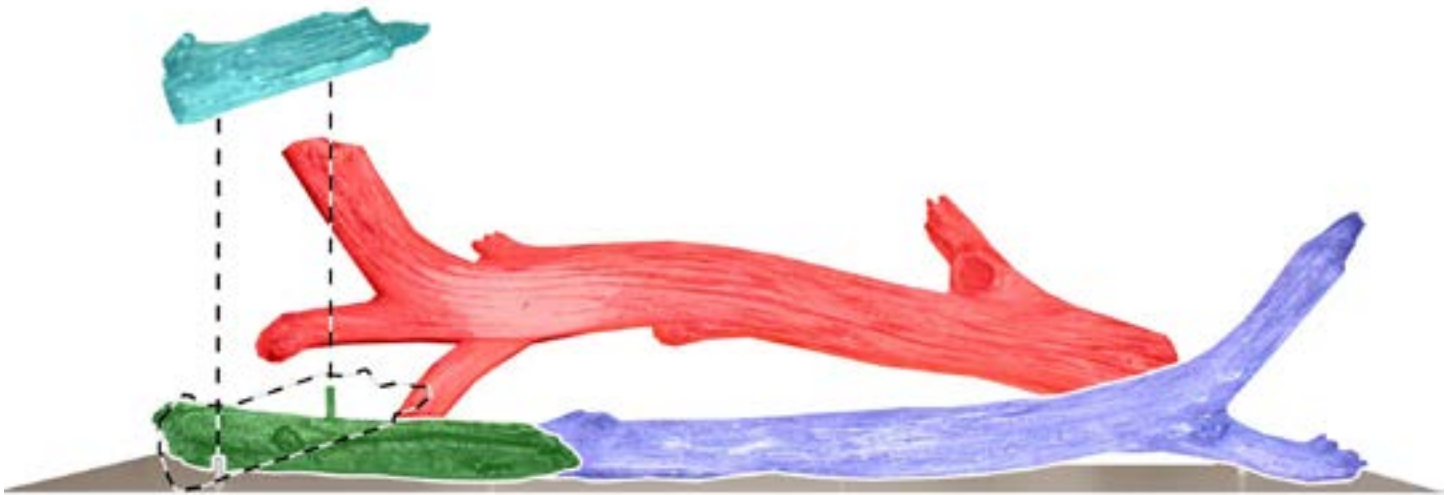

Front View

7. Replace the glass front into the fireplace by placing the right side into the slots in the firebox. Carefully angle in the left side of the glass and then slide the glass to the left. Settle the glass into the slots by gently lowering it.

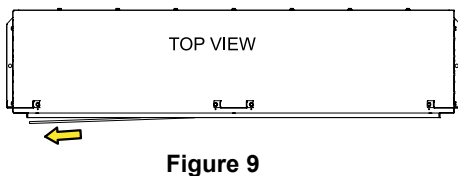
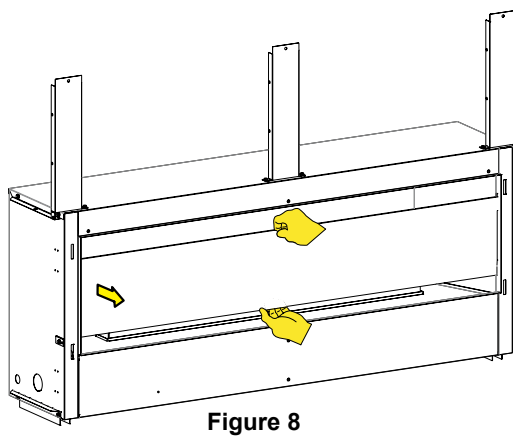
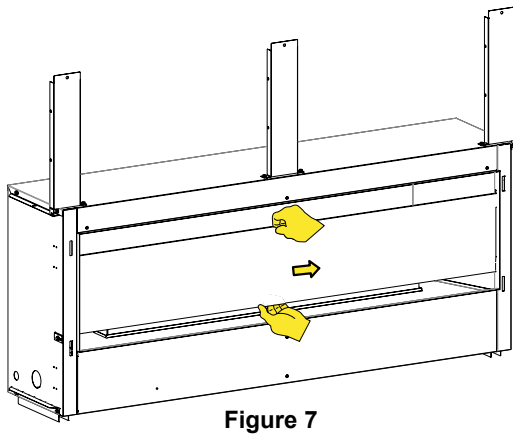
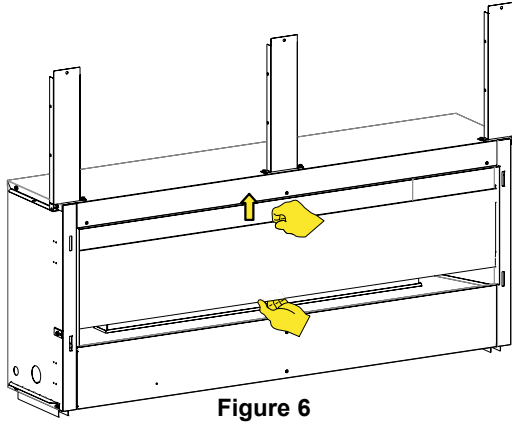

Use a clean cloth to wipe away any fingerprints on the glass before lighting the fireplace. The glass should be cleaned with an ammonia free cleaner. Ammonia can etch and stain glass when heated.

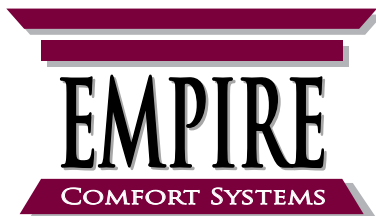

Empire Comfort Systems Inc.
918 Freeburg Ave. Belleville, IL 62220

If you have a general question about our products, please e-mail us at
info@empirecomfort.com.

If you have a service or repair question, please contact your dealer.

www.empirecomfort.com