

SINCE 1932

INSTALLATION INSTRUCTIONS AND OWNER'S MANUAL

INSTALLER: Leave this manual with the appliance.
CONSUMER: Retain this manual for future reference.

LUXURY DIRECT VENT GAS FIREPLACE

MULTI-FUNCTION REMOTE SERIES

Contemporary

DVLT(36,42)FP92(N,P)-2
DVTT36FP92(N,P)-2

Traditional

DVTT42FP92(N,P)-3

UL FILE NO. MH45034

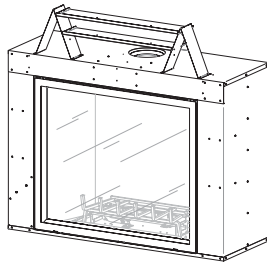

⚠ WARNING

FIRE OR EXPLOSION HAZARD

Failure to follow safety warnings exactly could result in serious injury, death or property damage.

- Do not store or use gasoline or other flammable vapors and liquids in the vicinity of this or any other appliance.
- **WHAT TO DO IF YOU SMELL GAS**
 - Do not try to light any appliance.
 - Do not touch any electrical switch; do not use any phone in your building.
 - Leave the building immediately.
 - Immediately call your gas supplier from a neighbor's phone. Follow the gas supplier's instructions.
 - If you cannot reach your gas supplier, call the fire department.
- Installation and service must be performed by a qualified installer, service agency or the gas supplier.

WARNING: If not installed, operated and maintained in accordance with the manufacturer's instructions, this product could expose you to substances in fuel or from fuel combustion which can cause death or serious illness.

This appliance may be installed in an aftermarket, permanently located, manufactured home (USA only) or mobile home, where not prohibited by state or local codes.

This appliance is only for use with the type of gas indicated on the rating plate. This appliance is not convertible for use with other gases, unless a certified kit is used.

⚠ WARNING



**HOT GLASS WILL CAUSE BURNS.
DO NOT TOUCH GLASS UNTIL COOLED.
NEVER ALLOW CHILDREN TO TOUCH GLASS.**

A barrier designed to reduce the risk of burns from the hot viewing glass is provided with this appliance and shall be installed for the protection of children and other at-risk individuals.

NATIONAL FIREPLACE INSTITUTE



CERTIFIED
www.nficertified.org

We suggest that our gas hearth products be installed and serviced by professionals who are certified in the U.S. by the National Fireplace Institute® (NFI) as NFI Gas Specialists.

BEFORE YOU START

1. Read the safety information on Pages 56 - 57.
2. If located in the Commonwealth of Massachusetts, please note the special requirements on page 58.
3. Where are you going to install the unit? See page 9.
4. Frame the opening. See page 10.
5. Install the gas lines. See page 8.
6. Install the wiring. See page 42.
7. Install the venting. See pages 14 - 19.
8. Install the fireplace. See pages 10 - 13.
9. Install the logs. See page 29 - 37.
10. Light the fireplace and troubleshoot. See pages 39 & 41.
11. Show the homeowner how to operate the fireplace.
12. Show the homeowner how to do the basic maintenance.

TABLE OF CONTENTS

SECTION	PAGE
INTRODUCTION	4
SPECIFICATIONS	5
FIREPLACE DIMENSIONS	6
CLEARANCES	7
GAS SUPPLY	8
LOCATING FIREPLACE	9
INSTALLATION	10 - 13
VENTING FIREPLACE	14 - 17
EXAMPLES - VENT RUN	18 - 19
TERMINATION CLEARANCES	20
VENT TERMINATION CLEARANCES	21
VENT SYSTEM IDENTIFICATION	22
VENTING FRAMING AND FINISHING	23 - 25
HORIZONTAL TERMINATION	26
VERTICAL TERMINATION	27 - 28
DVTT36 LOG IDENTIFICATION	29
DVTT36 LOG PLACEMENT	30 - 32
DVTT42 LOG IDENTIFICATION	33
DVTT42 LOG PLACEMENT	34 - 37
DVLT36 AND DVLT42 GLASS MEDIA INSTALLATION	37
BARRIER INSTALLATION	38
MULTIFUNCTION REMOTE LIGHTING INSTRUCTIONS	39
MULTIFUNCTION REMOTE OPERATING INSTRUCTIONS	40 - 41
MULTIFUNCTION REMOTE WIRING DIAGRAM	42
PREMIUM MULTIFUNCTION REMOTE OPERATION INSTRUCTIONS	43 - 45
MAINTENANCE AND SERVICE	46 - 47
ACCESSORIES	47
DVLT(36,42)FP92 REPLACEMENT PARTS LIST	48
DVLT(36,42)FP92 EXPLODED VIEW	49
DVTT(36,42)FP92 REPLACEMENT PARTS LIST	50
DVTT(36,42)FP92 EXPLODED VIEW	51
MASTER PARTS DISTRIBUTOR LIST	52
HOW TO ORDER REPAIR PARTS	52
JUNCTION BOX WIRING INSTALLATION INSTRUCTIONS	53
ACCENT LAMP LIGHT REPLACEMENT	53 - 54
WARRANTY TERMS	55
IMPORTANT SAFETY INFORMATION	56
SAFETY INFORMATION FOR USERS OF LP-GAS	57
REQUIREMENTS FOR MASSACHUSETTS	58
APPLIANCE SERVICE HISTORY	59

INTRODUCTION

Instructions to Installer

1. Installer must leave instruction manual with owner after installation.
2. Installer must have owner fill out and mail warranty card supplied with the fireplace.
3. Installer should show owner how to start and operate the fireplace.

This direct vent gas fireplace heater is designed to operate with all combustion air being siphoned from the outside of the building and all exhaust gases expelled to the outside of the building. The information contained in this manual pertains to all models and gas control systems unless otherwise noted.

WARNING

This unit is not for use with solid fuels.

Appliance Certification

This fireplace is design certified in accordance with American National Standard/CSA Standard ANSI Z21.50/CSA 2.22 and by Underwriters Laboratories as a Direct Vent Gas Fireplace and shall be installed according to these instructions.

Consult your local building code agency, prior to installation, to ensure compliance with local codes-including permits and inspections.

The fireplace, when installed, must be electrically grounded in accordance with local codes or, in absence of local codes, with the *National Electric Code ANSI/NFPA 70* or *Canadian Electric code, CSA C22.1*, if an external electrical source is utilized.

These models may be installed in a bedroom or bed-sitting room in the U.S.A. and Canada.

Qualified Installing Agency

Installation and replacement of gas piping, gas utilization equipment or accessories and repair and servicing of equipment shall be performed only by a qualified agency. The term "qualified agency" means any individual, firm, corporation or company which either in person or through a representative is engaged in and is responsible for (a) the installation or replacement of gas piping or (b) the connection, installation, repair or servicing of equipment, who is experienced in such work, familiar with all precautions required and has complied with all the requirements of the authority having jurisdiction.

State of Massachusetts: The installation must be made by a licensed plumber or gas fitter in the Commonwealth of Massachusetts.

The installation must conform with local codes or, in the absence of local codes, with the *National Fuel Gas Code ANSI Z223.1/NFPA 54* Natural Gas and Propane Installation Code*, or *CSA B149.1 in Canada*. *Available from the American National Standards Institute, Inc. 11 West 42nd St., New York, N.Y. 10036.

WARNING

ANY CHANGE TO THIS FIREPLACE OR ITS CONTROLS CAN BE DANGEROUS.

Improper installation or use of the fireplace can cause serious injury or death from fire, burns, explosions, or carbon monoxide poisoning.

Any alteration of the original design, installed other than as shown in these instructions or use with a type of gas not shown on the rating plate is the responsibility of the person and company making the change.

Important

All correspondence should refer to complete Model Number, Serial Number and type of gas.

High Altitude

When installing this unit at an elevation above 2000 feet (in the United States) it may be necessary to decrease the input rating by changing the existing burner orifice to a smaller size. Generally, input should be reduced 4 percent for each 1000 feet above sea level. However, if the heating value of the gas has been reduced, this general rule may not apply. Check with local gas utility for proper orifice size identification.

Canadian High Altitude

Altitude: 0-4500 feet (0-1370 m)

When installing this unit at an elevation above 4500 feet (in Canada), check with local authorities.

Consult your local gas utility for assistance in determining the proper orifice for location.

Preparation

This direct vent gas fireplace and its components are tested and safe when installed in accordance with this Installation Manual. Report to your dealer any parts damaged in shipment, specifically check glass condition. Do not install unit with damaged, incomplete, or substitute parts. Read all instructions before starting installation and follow these instructions carefully during installation to insure maximum benefit and safety. Failure to follow them will void your warranty and may present a fire hazard.

The warranty will be voided by, and the warranter disclaims any responsibility for the following actions:

- Installation of any damaged fireplace or vent system component.
- Modification of the fireplace or direct vent system.
- Installation other than as instructed by Empire Comfort Systems, Inc.
- Improper positioning of the logs, glass door or decorative rock.
- Installation and/or use of any component part not manufactured or approved by manufacturer.

SPECIFICATIONS

	DVLT36 NAT DVTT36 NAT	DVLT36 LP DVTT36 LP	DVLT42 NAT DVTT42NAT	DVLT42 LP DVTT42LP
Input Btu/hr Maximum	40,000	40,000	50,000	50,000
Input Btu/hr Minimum	23,000	23,000	25,000	26,500
KWH (Maximum)	11.7	11.7	14.70	14.7
KWH (Minimum)	6.7	6.7	7.3	7.8
Orifice - Front	#43	1.35 mm	#39	#53
Orifice - Rear	#43	#55	#39	#53
Air Shutter Opening - Front	DVLT36 - 1/8" DVTT36 - 3/8"	DVLT36 - 1/4" DVTT36 - Wide Open	DVLT42 - 1/8" DVTT42 - 3/8"	DVLT42 - Wide Open DVTT42 - Wide Open
Air Shutter Opening - Rear	DVLT36 - 1/8" DVTT36 - 3/8"	DVLT36 - 3/8" DVTT36 - Wide Open	DVLT42 - 1/8" DVTT42 - 3/8"	DVLT42 - 3/8" DVTT42 - Wide Open
Height without standoff	39-1/4" (997mm)	39-1/4" (997mm)	45-1/4" (1,149mm)	45-1/4" (1,149mm)
Width	55" (1,397mm)	55" (1,397mm)	61" (1,549mm)	61" (1,549mm)
Depth	22" (559mm)	22" (559mm)	22" (559mm)	22" (559mm)
Gas Inlet Shutoff Valve (Pipe)	1/2 NPT	1/2 NPT	1/2 NPT	1/2 NPT

Notice: Air shutter settings are factory minimum settings. Some venting configurations may require minor air shutter adjustments for optimum performance.

FIREPLACE DIMENSIONS

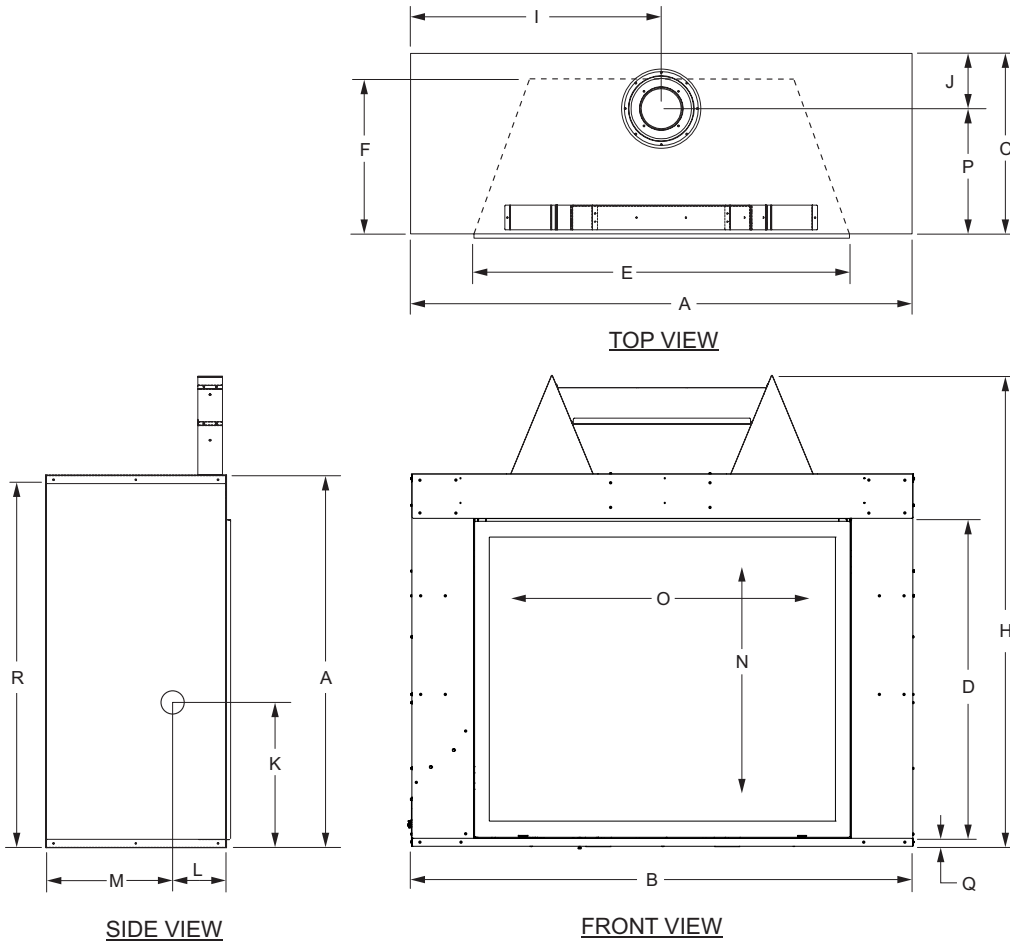

INDEX LETTER	DIMENSION DESCRIPTION	DVTT36 & DVLT36	DVTT42 & DVLT42
		Dimensions in Inches	
A	The maximum height of firebox face (excluding standoffs)	39-5/16	45-5/16
B	The maximum width of the firebox face (excluding nailing flanges)	55	61
C	The maximum depth of the firebox	22	22
D	The height of the firebox opening	32-7/8	38-7/8
E	The width of the firebox opening	39-7/8	45-7/8
F	The interior depth of the firebox (not shown)	18-7/8	18-7/8
H	The height to the firebox standoffs	51-5/16	57-5/16
I	Width from the left side of the box to the centerline of vent	27-1/2	30-1/2
J	Depth from back of box to centerline of top vent	6-7/8	6-7/8
K	Height from the bottom of the box to the gas line opening	15-1/8	15-1/8
L	Depth from the front of the box to gas line opening	5	5
M	Depth from rear of box to gas line opening	17	17
N	Glass height	31-1/8	37-1/8
O	Glass width	37	43
P	Depth from front of box to centerline of vent	15-3/16	15-3/16
Q	Distance from floor to fireplace opening	2	2
R	Height from floor to vent collar	38-3/4	44-3/4

N/A - Not applicable for this unit.

CLEARANCES

Clearance to Combustibles	
Back	1-1/2" (38 mm)
Side	1-1/2" (38 mm)
Floor	0" (0 mm)
Top Stand-off	12" (305 mm)
Top Framing Edge	12" (305 mm)
Minimum Height Floor To Ceiling	96" (2439mm)
Vertical Venting	1" (25.4 mm)

Optional Recessed Area

If a recess is desired, a 5-1/2" (127mm) deep (face of finishing material to back of pocket) may be framed. Use 3/4" (19mm) wood or steel framing. See Figure 1.

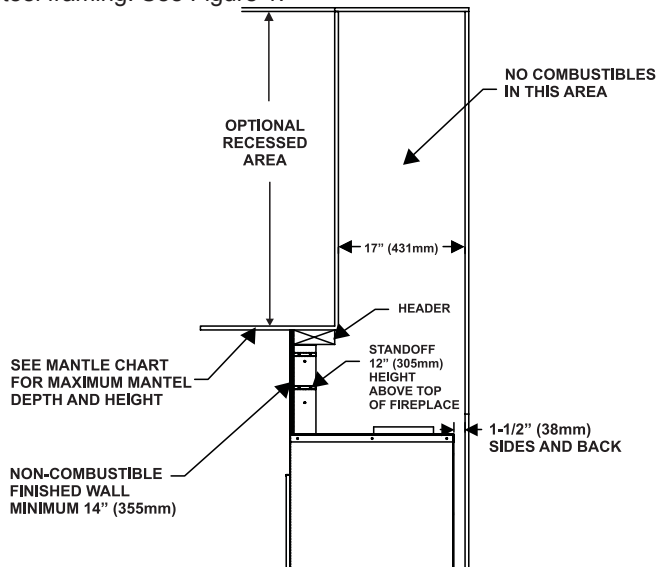

Figure 1

Television Considerations

Installing a television above a fireplace has become a desirable feature; however, the following information should be considered. All fireplaces, whether decorative or heater rated create heat. Most television manufacturers recommend not placing a television near a heat source. Because there is a large variety of television manufactures, styles and sizes, it is impractical to test every potential installation. If you choose to install a television above or near your fireplace, understand that Empire Comfort Systems accepts no responsibility for this decision and any injury or damage due to this application is the sole responsibility of the owner. Additionally, it is highly recommended to turn off the fireplace and let it cool down before servicing or using the operational buttons located on the television. In all cases, the television manufacturer's instructions and warnings should be followed.

Combustible Material

No greeting cards, stockings or ornamentation of any type should be placed on or attached to the fireplace. The flow of heat can ignite combustibles. See Figure 3.

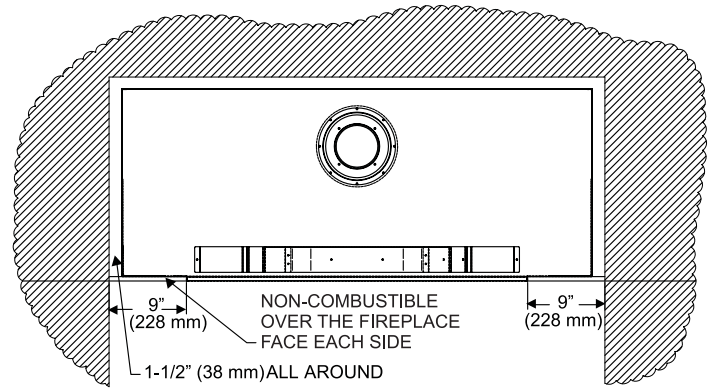

Figure 2

Mantel Chart

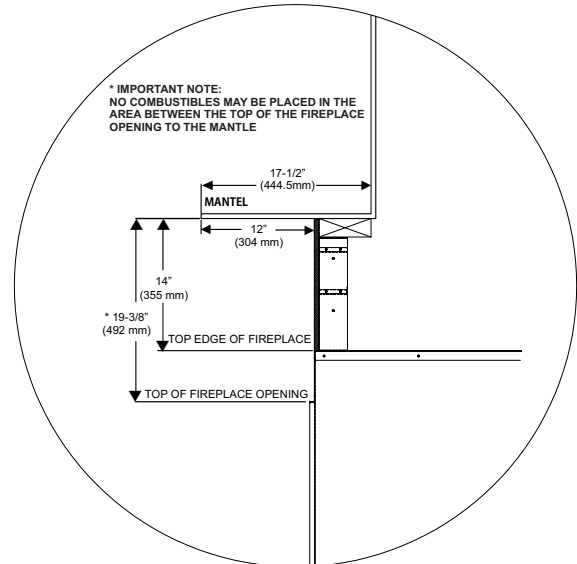

Figure 3

Ceiling Height and Side Wall Clearances

Minimum ceiling height is 96" (2438 mm)

Clearance from side of fireplace to adjacent sidewall is 6" (152mm).

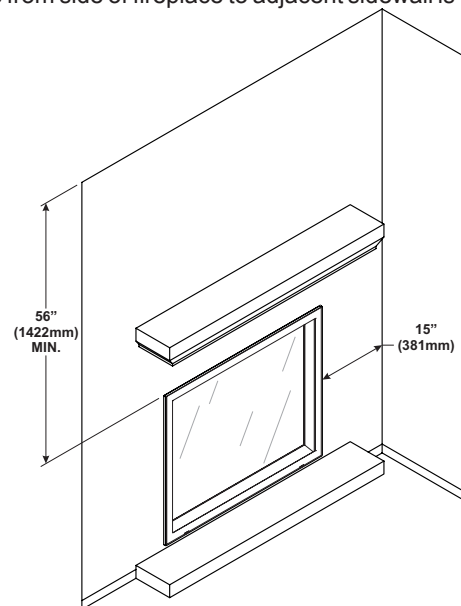

Figure 4

GAS SUPPLY

The gas pipeline can be brought in through the left side of the appliance. Consult the current National Fuel Gas Code, ANSI Z223.1 CAN/CGA-B149 (.1 or .2) installation code.

Recommended Gas Pipe Diameter				
Pipe Length	Schedule 40 Pipe Inside Diameter		Tubing, Type L Outside Diameter	
	Nat.	L.P.	Nat.	L.P.
0-10ft 0-3m	1/2" 12.7mm	3/8" 9.5mm	1/2" 12.7mm	3/8" 9.5mm
11-40ft 4-12m	1/2" 12.7mm	1/2" 12.7mm	5/8" 15.9mm	1/2" 12.7mm
41-100ft 13-30m	1/2" 12.7mm	1/2" 12.7mm	3/4" 19mm	1/2" 12.7mm
101-150ft 31-46m	3/4" 19mm	1/2" 12.7mm	7/8" 22.2mm	3/4" 19mm

Notice: Never use plastic pipe. Check to confirm whether your local codes allow copper tubing or galvanized.

Notice: Since some municipalities have additional local codes, it is always best to consult your local authority and installation code. The use of the following gas connectors is recommended:

- ANSI Z21.24 Appliance Connectors of Corrugated Metal Tubing and Fittings.
- ANSI Z21.45 Assembled Flexible Appliance Connectors of Other Than All-Metal Construction

The above connectors may be used if acceptable by the authority having jurisdiction. The state of Massachusetts requires that a flexible appliance connector cannot exceed three feet in length.

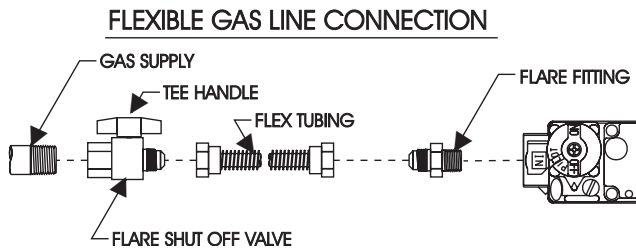

Figure 5

	Gas Supply Pressure (inches w.c.)		
	Minimum	Normal	Maximum
Natural Gas	5.0"	7.0"	*14.0"
LP (Propane)	10.8"	11.0"	14.0"
	Manifold Pressure (inches w.c.)		
	Normal (HI)		
Natural Gas	3.5"		
LP (Propane)	10.0"		

Installing a New Main Gas Cock

Each appliance should have its own manual gas cock.

A manual main gas cock should be located in the vicinity of the unit. Where none exists, or where its size or location is not adequate, contact your local authorized installer for installation or relocation.

Compounds used on threaded joints of gas piping shall be resistant to the action of liquefied petroleum gases. The gas lines must be checked for leaks by the installer. This should be done with a soap solution watching for bubbles on all exposed connections, and if unexposed, a pressure test should be made.

Never use an exposed flame to check for leaks. Appliance must be disconnected from piping at inlet of control valve and pipe capped or plugged for pressure test. Never pressure test with appliance connected; control valve will sustain damage!

Notice: The gas controls are equipped with a captured screw type pressure test point, therefore it is not necessary to provide a 1/8" test point up stream of the control.

When using copper or flex connector use only approved fittings.

The appliance and it's individual shut off valve must be disconnected from supply piping system during any pressure testing of that system at test pressures in excess of 1/2 psig (3.5kPa).

The appliance must be isolated from the gas supply piping system by closing its individual manual shut off valve during any pressure testing of the gas supply piping system at test pressures equal to or less than 1/2 psig (3.5kPa).

Attention! If one of the procedures results in pressures in excess of 1/2 psig (14" w.c.) (3.5 kPa) on the fireplace gas valve, it will result in a hazardous condition.

Checking Manifold Pressures

Both Propane and Natural gas valves have a built-in pressure regulator in the gas valve. Natural gas models will have a manifold pressure of approximately 3.5" w.c. (.871kPa) at the valve outlet with the inlet pressure to the valve from a minimum of 5.0" w.c. (1.245kPa) for the purpose of input adjustment to a maximum of 14.0" w.c. (3.484kPa). Propane gas models will have a manifold pressure approximately 10.0" w.c. (2.49kPa) at the valve outlet with the inlet pressure to the valve from a minimum of 10.8" w.c. (2.68kPa) for the purpose of input adjustment to a maximum of 14.0" w.c. (3.484kPa).

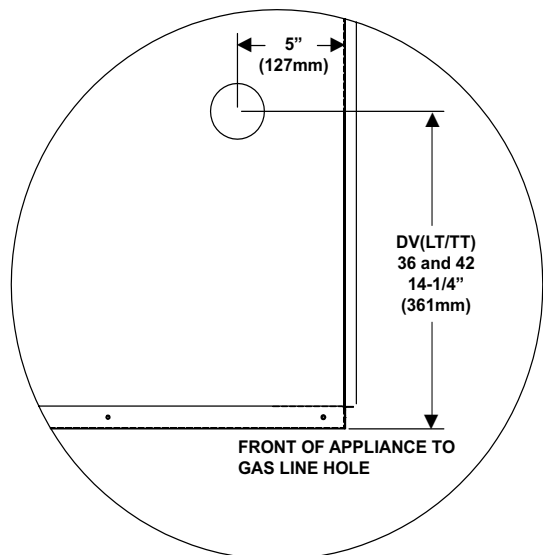

Figure 6

LOCATING FIREPLACE

Notice: Island and Room Divider installation is possible as long as the horizontal portion of the vent system does not exceed 20 feet (6,096mm) with a minimum vertical run of 8 feet (2,438mm). See details in Venting Section. See **Figure 7**.

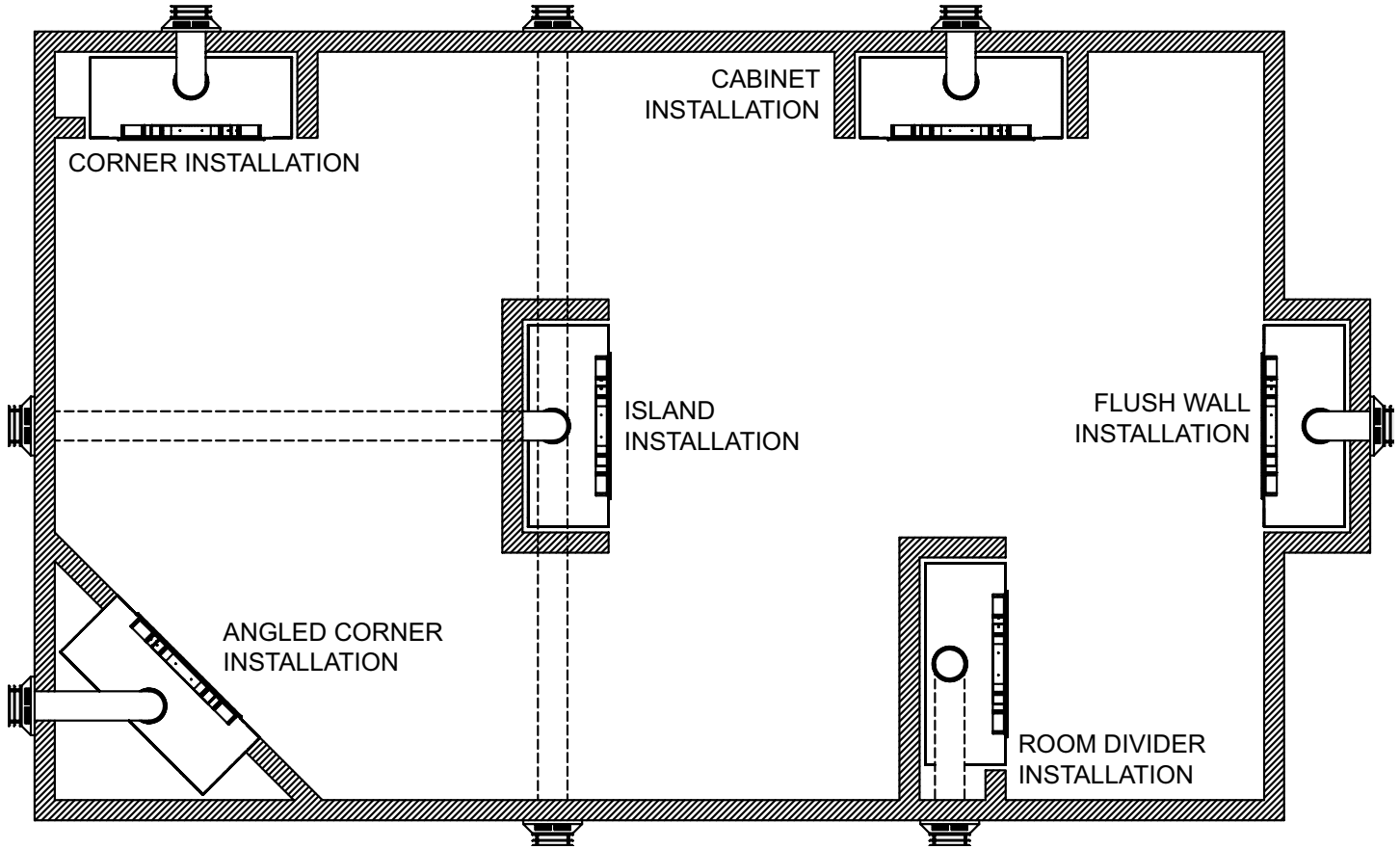

Figure 7

INSTALLATION

Framing

Fireplace framing can be built before or after the fireplace is set in place. Framing should be positioned to accommodate wall covering and fireplace facing material. The fireplace framing should be constructed of 2 x 4 lumber or heavier. The framing headers may rest on the fireplace standoffs. Refer to Figure 8 for minimum framing dimensions.

CAUTION

MEASURE FIREPLACE DIMENSIONS AND VERIFY FRAMING METHODS, AND WALL COVERING DETAILS BEFORE FRAMING CONSTRUCTION BEGINS.

Framing dimension "A" includes a 12" (304 mm) clearance for standoffs on firebox. After installing firebox into framing, the finished wall surface must cover the 12" (304mm) opening above the firebox. Board provided with fireplace.

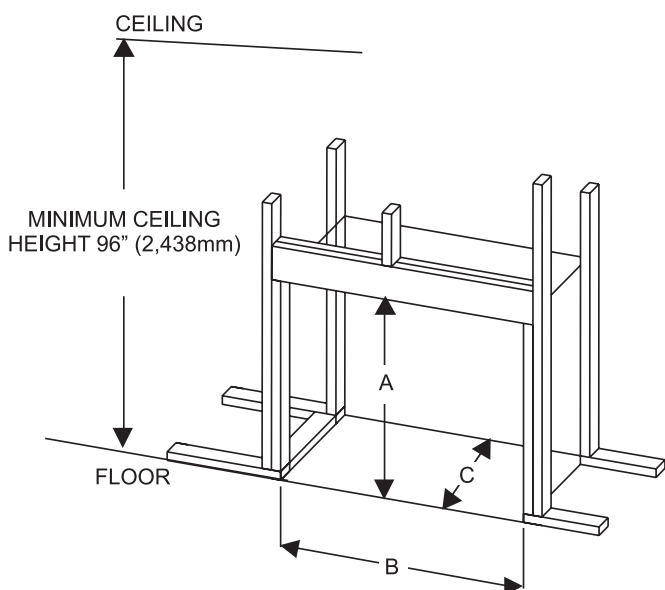

	DVLT/DVTT36	DVLT/DVTT42
A	51-1/2" (1,308mm)	57-1/2" (1,460mm)
B	58" (1,473mm)	64" (1,625mm)
C	23-1/2" (597mm)	23-1/2" (597mm)

Figure 8

Attention: If a base or mantel is not used and the appliance is installed directly on carpeting, tile or other combustible material other than wood flooring, it shall be installed on a metal or wood panel extending the full width and depth of the appliance. The vertical dimension in Figure 8 must be adjusted when a metal or wood panel is placed beneath the appliance.

Attention: Cold climate installation recommendation: When installing this unit against a non-insulated exterior wall, it is recommended that the outer walls be insulated to conform to applicable insulation codes.

Firebox Standoff Installation

1. Remove the two #10 x 1/2" screws, two support braces and two standoffs from firebox rear as shown in Figure 9. Do not discard any of the hardware.

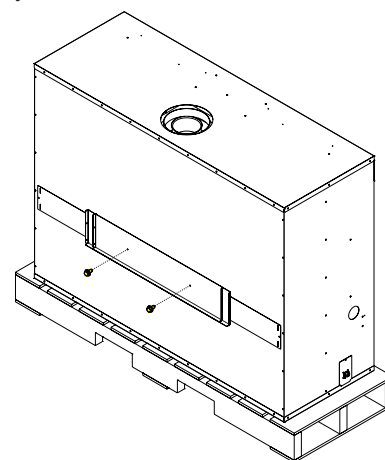

Figure 9

2. Bend the standoffs as shown in Figure 10.

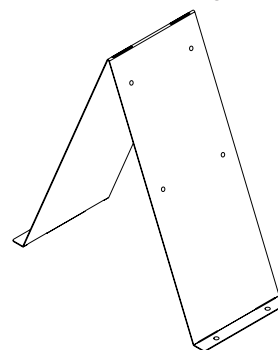

Figure 10

3. Use the two #10 x 1/2" screws removed in Step 1 and four #10 x 1/2" screws provided in the hardware package to secure the standoffs to the firebox top (3 each side. See Figure 11.
4. Secure the short and long supports to the standoffs using eight 10 x 1/2" screws (4 each support, 2 each side). See Figure 11.

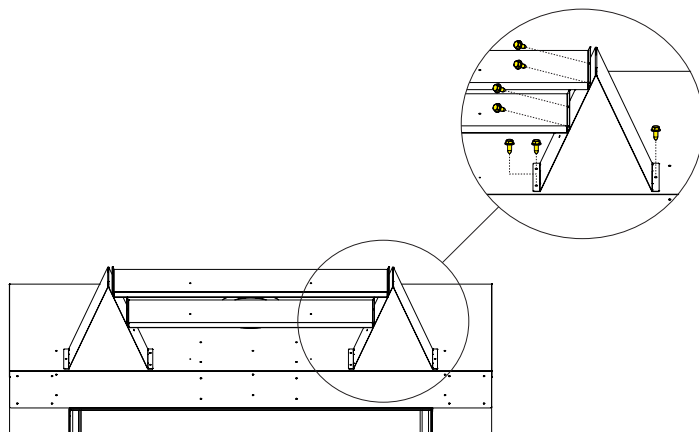

Figure 11

INSTALLATION (continued)

Flush Mount Installation

The fireplace must extend 3/4" (19mm) beyond finished wall surface when using a flush mount. Refer to Figure 12 to locate nailing flanges on fireplace sides. Mark and drill two 1/8" holes into fireplace side to mount each nailing flange. Use eight 1/2" hex-head screws supplied in hardware package to attach nailing flanges to fireplace sides.

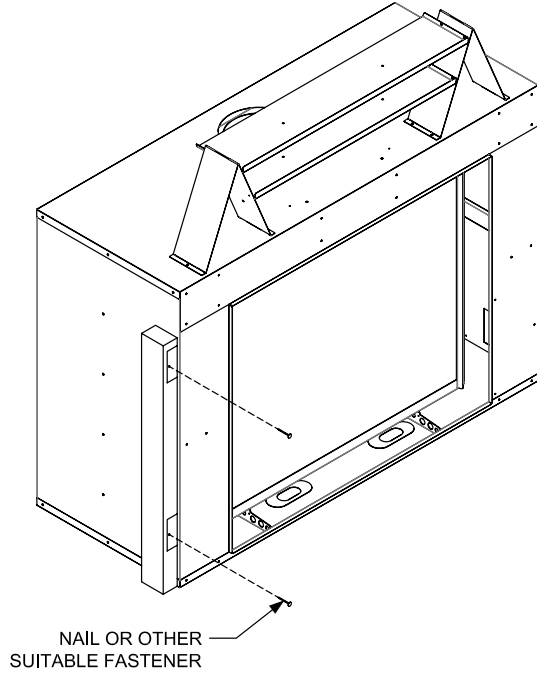

Figure 12

Flush Wall Installation

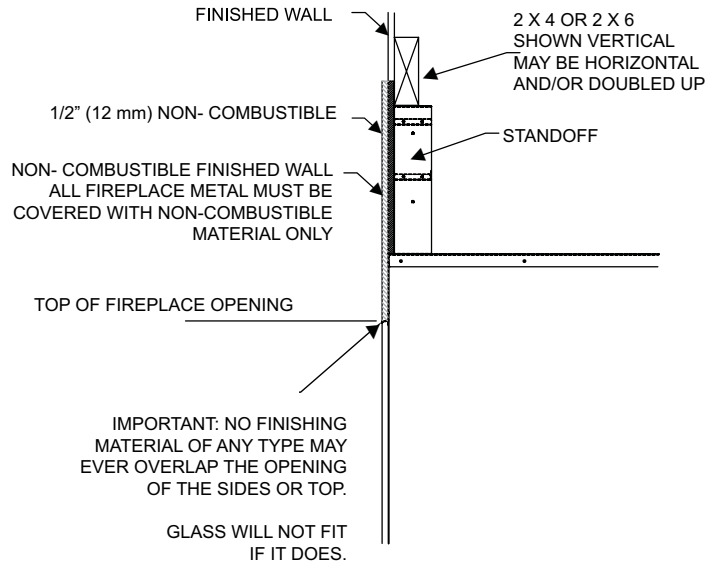

Figure 13

Framing and Finishing

1. Choose unit location.
2. Frame in fireplace with a header across the top. It is important to allow for finished face when setting the depth of the frame.
3. Attach fireplace to frame. **See Figure 14.**

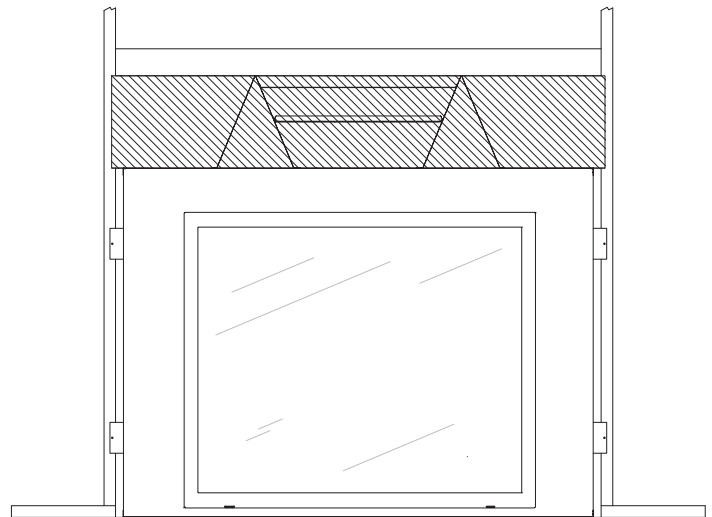

Figure 14

INSTALLATION (continued)

Vent Pipe Clearance

Note: Maintain one inch of clearance around vertical vent pipe (after the first 96" framing). **See Figure 15.**

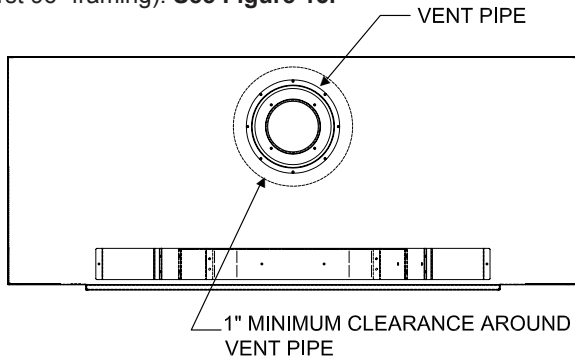

Figure 15

For horizontal vent, maintain a minimum 1" clearance to the bottom and sides of the vent, and 3" clearance to combustibles above the vent pipe. **See Figure 16.**

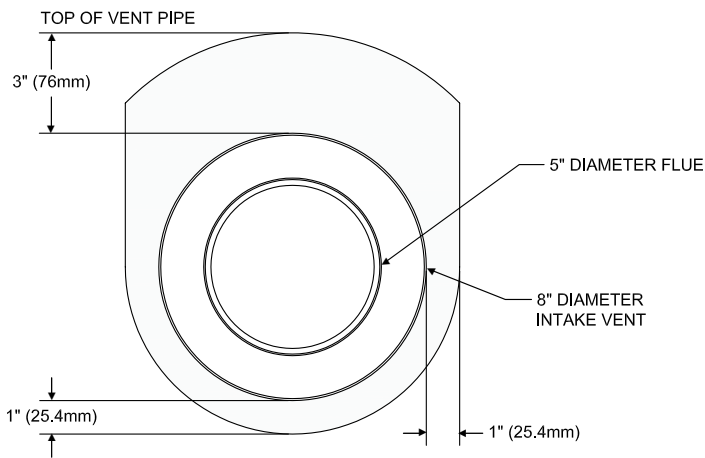

Figure 16

Combustible Surround Installation

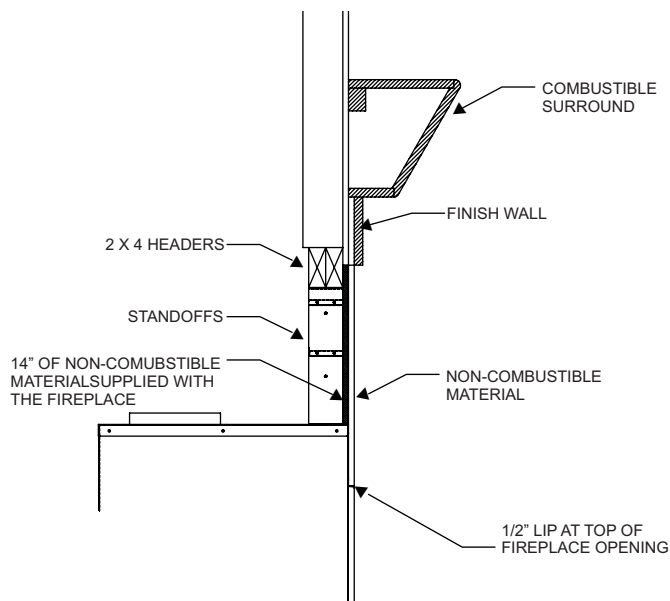

Figure 17

Finishing

Finish the walls with the material of your choice. Figure 3 on page 7 shows the minimum vertical and corresponding maximum horizontal dimensions of mantels or other combustible projections above the top front edge of the fireplace.

Only non-combustible materials may be used to cover the metal fireplace face. See Figure 2, Page 7.

WARNING

If the joints between the finished wall and the fireplace surround (top and sides) are sealed, a 300°F minimum sealant material must be used. These joints are not required to be sealed. Only non-combustible material (using 300°F minimum adhesive if needed), can be applied as facing to the fireplace surround.

Vent Runs

In planning the installation for the fireplace, it is necessary to install certain components before the appliance is completely positioned and installed. These include the direct vent system, gas piping for the appliance and the electrical wiring.

The appliance can be mounted on any of the following surfaces:

1. A flat, hard combustible surface.
2. A raised wooden platform.
3. Six supports. (Example: Six concrete masonry blocks.) These supports must be positioned so they contact all four perimeter edges on the bottom of the unit and under the center leg supports, if allowed by code.

VERTICAL, 90° ELBOW WITH HORIZONTAL TERMINATION

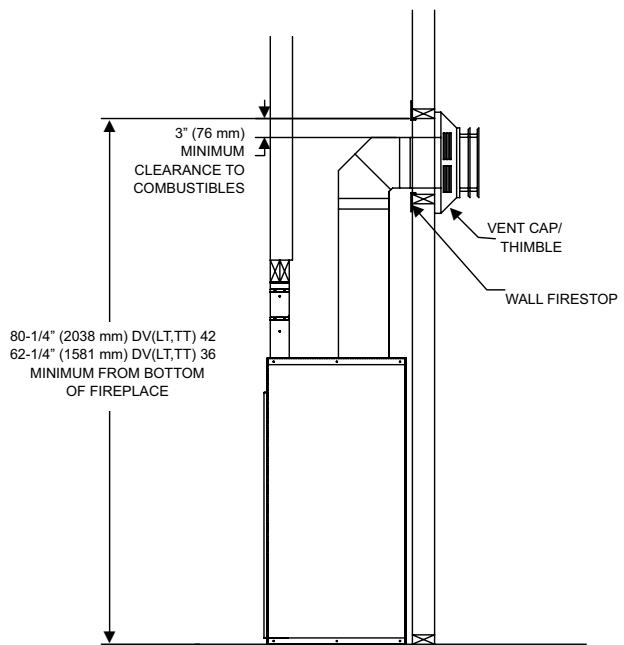
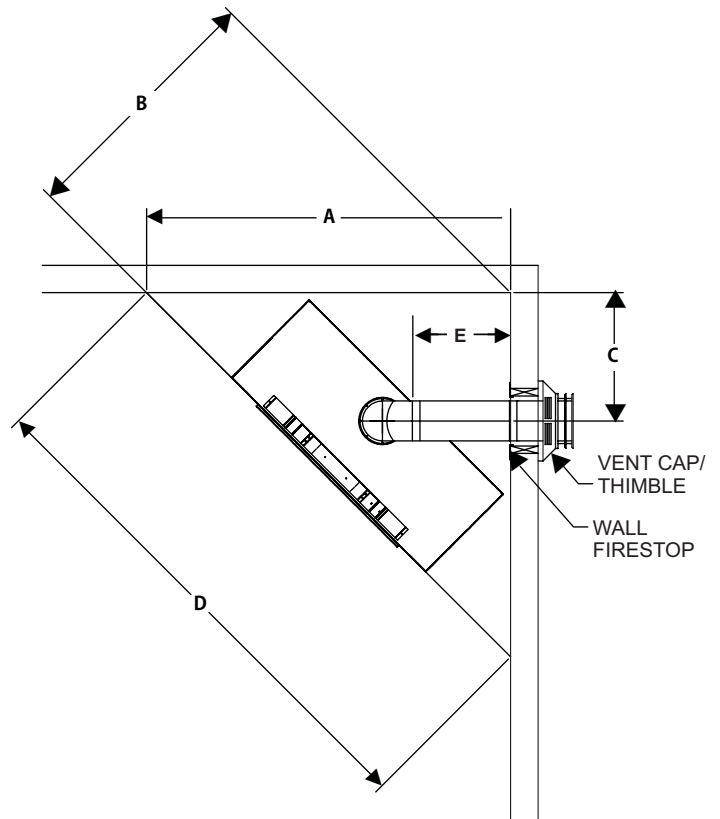
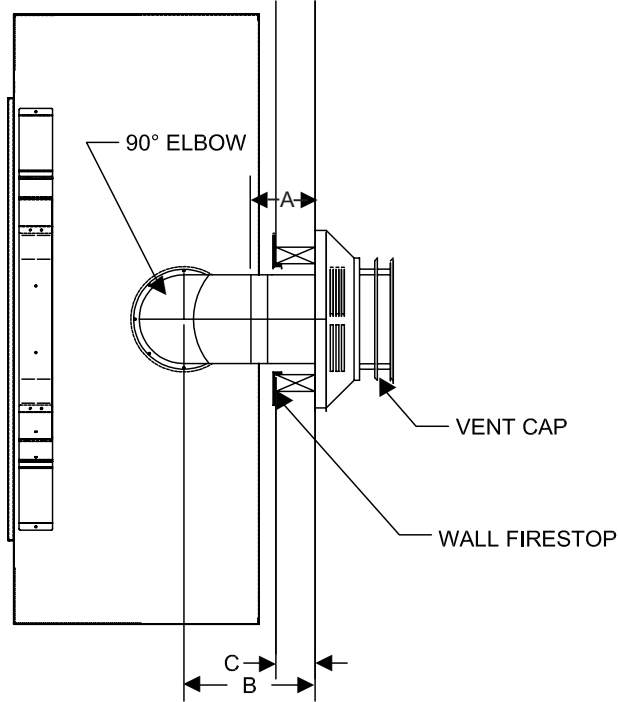

Figure 18

INSTALLATION (continued)

VERTICAL, 90° ELBOW TO HORIZONTAL OUT THE WALL



A	B	C
6 INCH	11-3/4" TO 12-3/4" (298mm TO 323mm)	4-3/4" TO 6-1/4" (121mm TO 159mm)
9 INCH	14-1/4" TO 15-3/4" (362mm TO 400mm)	7-3/4" TO 9-1/4" (197mm TO 235mm)
12 INCH	17-1/4" TO 18-3/4" (438mm TO 476mm)	10-3/4" TO 12-1/4" (273mm TO 311mm)

Figure 19
CORNER INSTALLATION VERTICAL, 90° ELBOW TO HORIZONTAL OUT THE WALL

	DVLT/DVTT36	DVLT/DVTT42
A	72-11/16" (1853 mm)	77-1/4" (1962 mm)
B	51-9/16" (1310 mm)	54-5/8" (1387 mm)
C	25-11/16" (652 mm)	27-7/8" (708 mm)
D	103-1/8" (2620 mm)	109-1/4" (2775 mm)
E	19-11/16" (500 mm)	21-7/8" (555 mm)

Figure 20

Corner installation may require more vertical than just the minimum required depending on wall thickness and horizontal dimension.

IMPORTANT:

MINIMUM HEIGHT OFF THE TOP REQUIREMENTS

DVLT36FP & DVTT36FP - MUST USE a 1 FT (305 mm) vent pipe as the first section BEFORE installing the elbow.

DVLT42FP & DVTT42FP - MUST USE a 2 FT (610 mm) vent pipe as the first section BEFORE installing the elbow.

VENTING FIREPLACE

To Use the Vent Graph

1. Determine the height of the center of the horizontal vent pipe. Using this dimension on the Sidewall Vent Graph, locate the point it intersects with the slanted graph line.
2. From the point of this intersection, draw a vertical line to the bottom of the graph.
3. Select the indicated dimension, and position the unit in accordance with same.

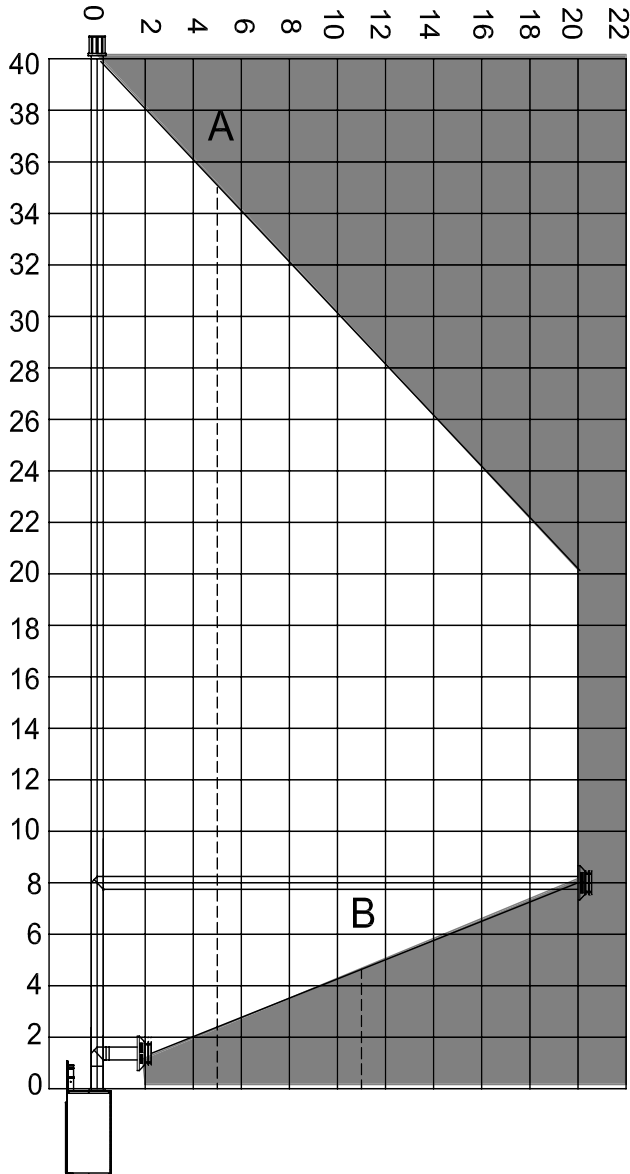

Figure 21 (DVLT36 and DVTT36)

- Acceptable vertical and horizontal vent run.
(40' maximum vertical and 20' maximum horizontal)
- Unacceptable vertical and horizontal vent run.

EXAMPLE A:

If the vertical dimension from the top of the unit is 35', the horizontal run to the outer wall flange must not exceed 5'.

EXAMPLE B:

DV(LT,TT)36: If the vertical dimension from the top of the unit is 4.5', the horizontal run to the outer wall flange must not exceed 11'.

DV(LT,TT)42: If the vertical dimension from the top of the unit is 5', the horizontal run to the outer wall flange must not exceed 11'.

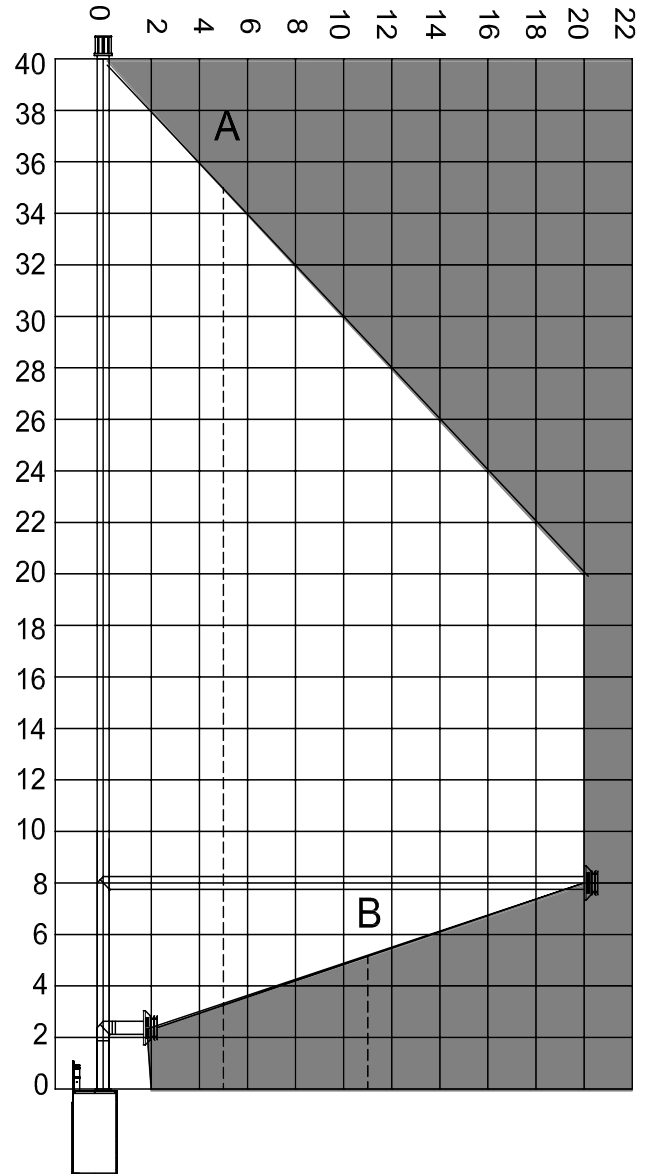

Figure 22 (DVLT42 and DVTT42)

Special Note: For each 45 degree elbow installed in the horizontal run, the length of the horizontal run MUST be reduced by 18" (45cm). This does not apply if the 45 degree elbows are installed on the vertical part of the vent system. Reduce 3' for every 90° elbow.

Example: According to the chart the maximum horizontal vent length is 20' and if two 45 degree elbows are required in the horizontal vent it must be reduced to 17'.

The maximum number of 45 degree elbows permitted per side wall installation is two (2). These elbows can be installed in either the vertical or horizontal run.

NOTE: The first elbow does not get counted.

VENTING FIREPLACE

Maximum horizontal run for a minimum vertical rise

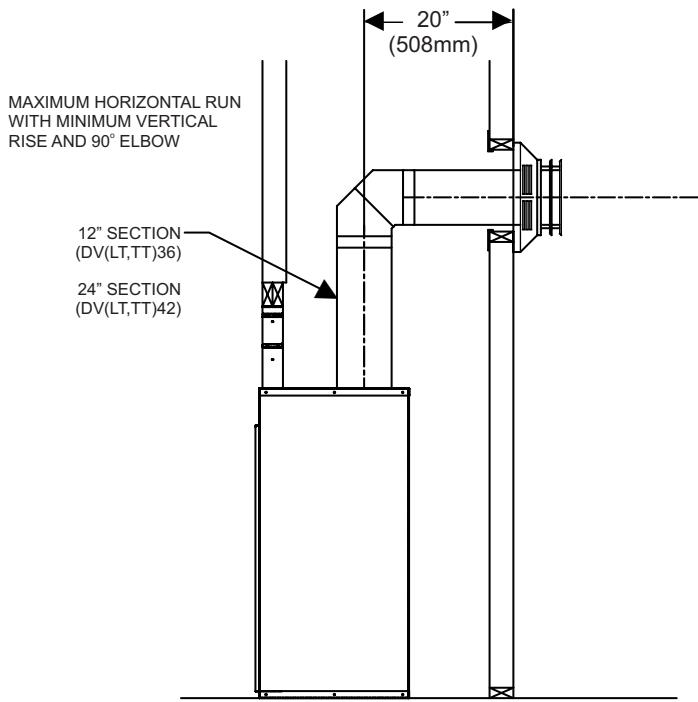

Figure 23

Minimum vertical rise for maximum horizontal run

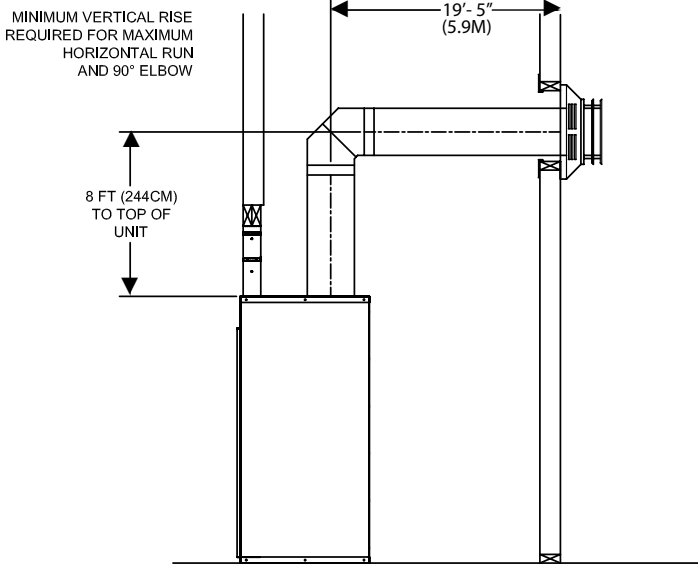

Figure 24

Below Grade Installation

When it is not possible to meet the required vent terminal clearances of 12" (305mm) above grade level, a snorkel kit is recommended. It allows installation depth down to 7" (178mm) below grade level. The 7" (178mm) is measured from the center of the horizontal vent pipe as it penetrates through the wall.

Ensure the sidewall venting clearances are observed. If venting system is installed below ground, we recommend a window well with adequate and proper drainage to be installed around the termination area.

Typical Basement Installation

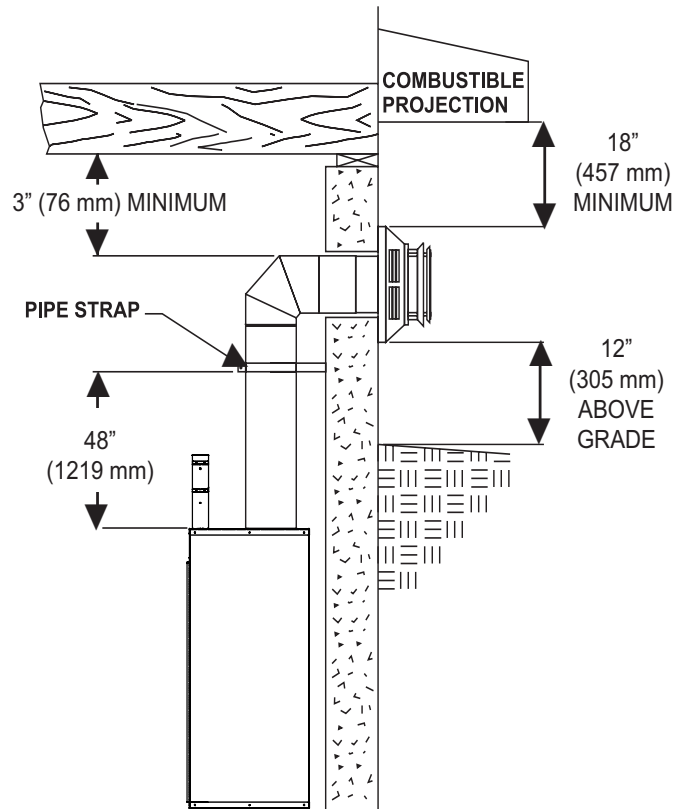
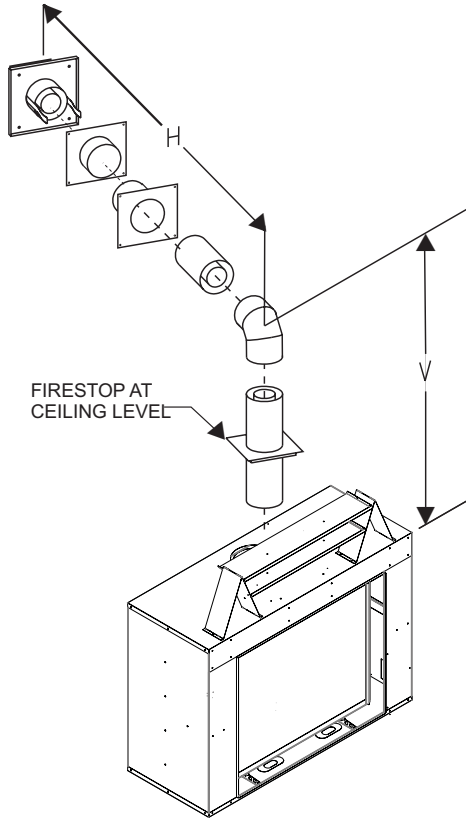

Figure 25

VENTING FIREPLACE

Examples of possible venting systems using one 90° elbow

Eight feet is listed as minimum vertical vent run with a maximum of 20 feet horizontal vent run. Vertical dimensions are based on centerline to centerline of pipe. Horizontal dimensions are based on centerline of pipe to end of termination.



SEE GRAPH FOR PERMISSIBLE
"H" AND "V" DIMENSIONS

Figure 26

Attention: Refer to Figures 21 and 22 for additional venting requirements.

Examples of possible venting systems using two 90° elbows

V is listed as minimum vertical dimensions and H1 + H2 is listed as total of maximum horizontal dimensions. The maximum vertical and horizontal distances for two 90° elbows as shown in Figure 27 is 37 feet.

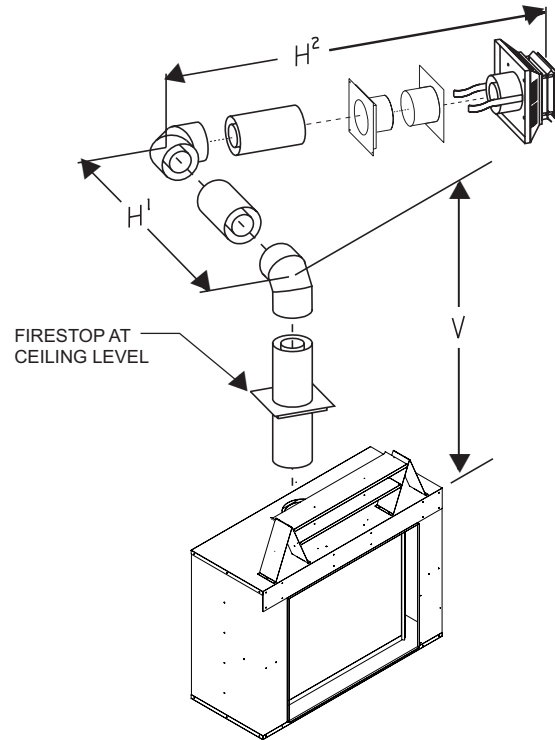

SEE GRAPH FOR PERMISSIBLE "H" AND "V" DIMENSIONS

NOTE: H1 AND H2 MUST BE ADDED TOGETHER TO USE GRAPH

Figure 27

MINIMUM HOLE LOCATION DIMENSIONS FOR THROUGH THE WALL HORIZONTAL INSTALLATIONS WITH 90 DEGREE ELBOW OFF TOP OF FIREPLACE

Positioning the Fireplace

Determine the exact position of the appliance so the direct vent termination will be centered (if possible) between two studs. This will avoid any extra framing. All vent kit pipes should be assembled on the unit after the unit is moved into the final position.

FIREPLACE SERIES	HARD ELBOW DIMENSIONS		
	A	B	C
DVLT/DVTT36	55-1/4" (1403 mm)	5" (127 mm)	7" (178 mm)
DVLT/DVTT42	73-1/4" (1861 mm)	5" (127 mm)	7" (178 mm)

VENTING FIREPLACE

Cutting the Hole

After the fireplace has been positioned in its permanent location, the hole through the exterior wall of the house can be cut. This hole must be 12" (305mm) high x 10" (254mm) wide with its center line determined by the amount of vertical rise and horizontal run of the termination. See Figure 28.

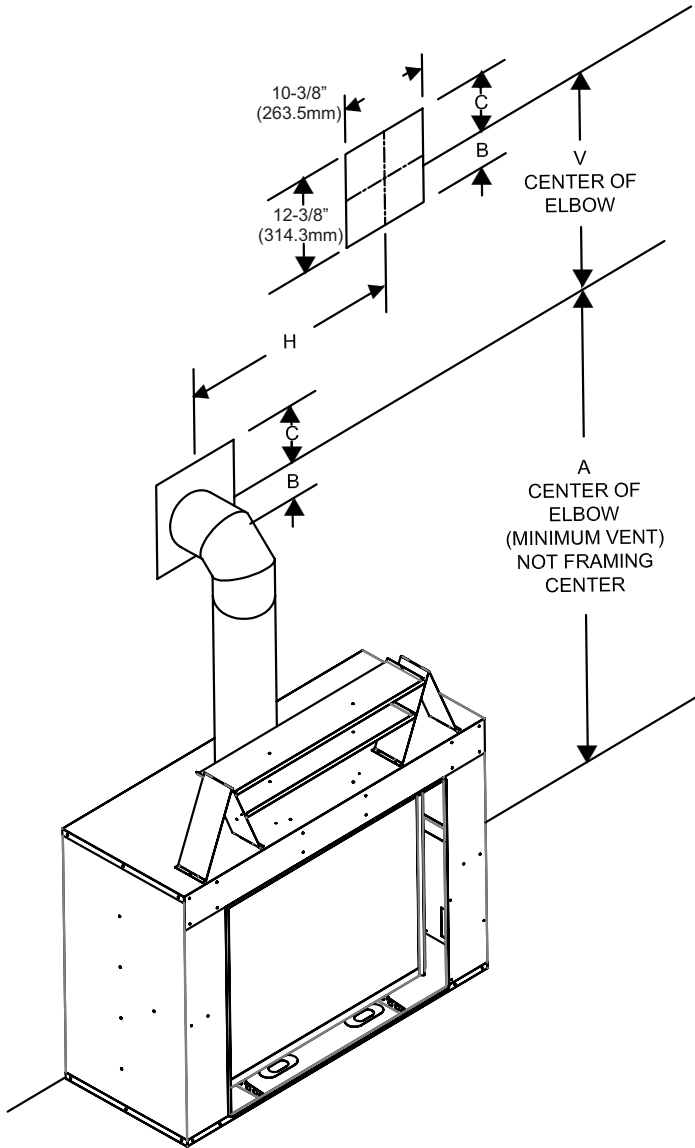

Figure 28

When locating the hole it must be noted that the bottom of the cap must be 12" (305mm) above the ground level, and top of the cap must be no less than 18" (457mm) below a combustible projection, and no closer than 9" (229mm) to any wall running parallel to vent termination. See Figure 29.

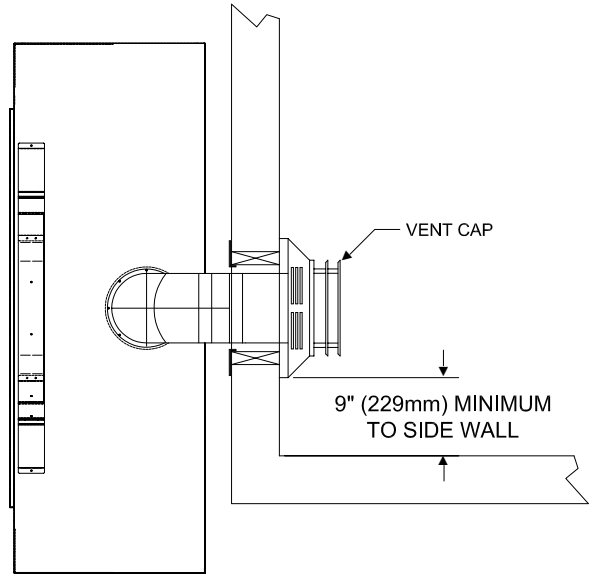
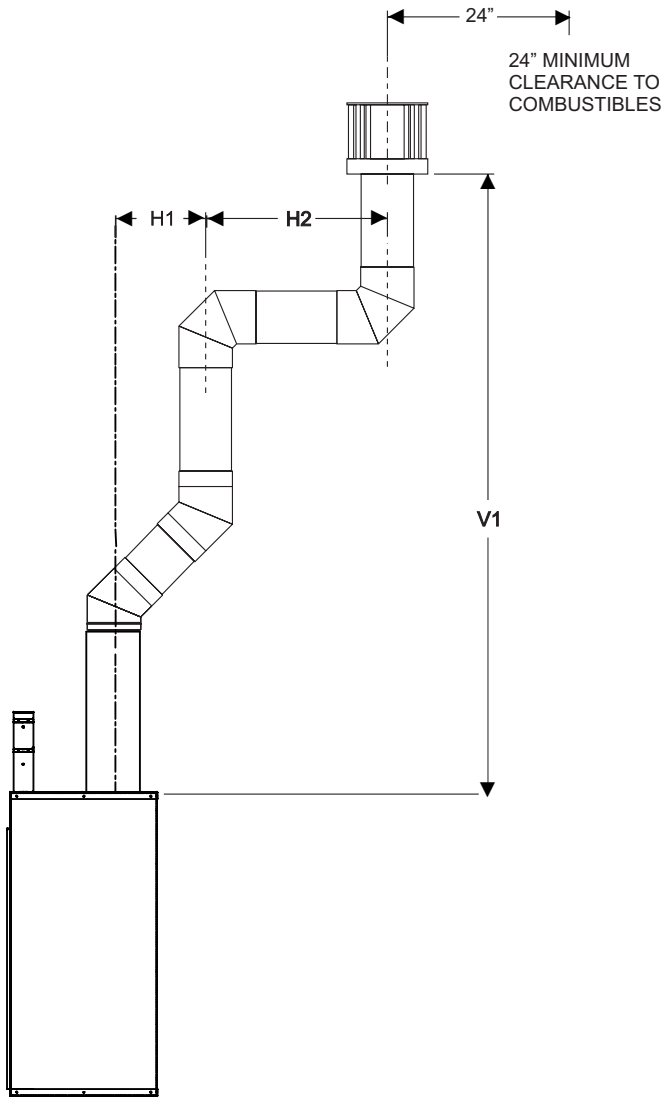

Figure 29

EXAMPLES - VENT RUN



EXAMPLE

If total horizontal needs to be 8', then the minimum required vertical is 6'.

$$H=8' (45^\circ + 90^\circ + 90^\circ) = 14' \text{ (equivalent horizontal)}$$

From the graph the required vertical is 6'.

Figure 30 - (DV(LT,TT)42)

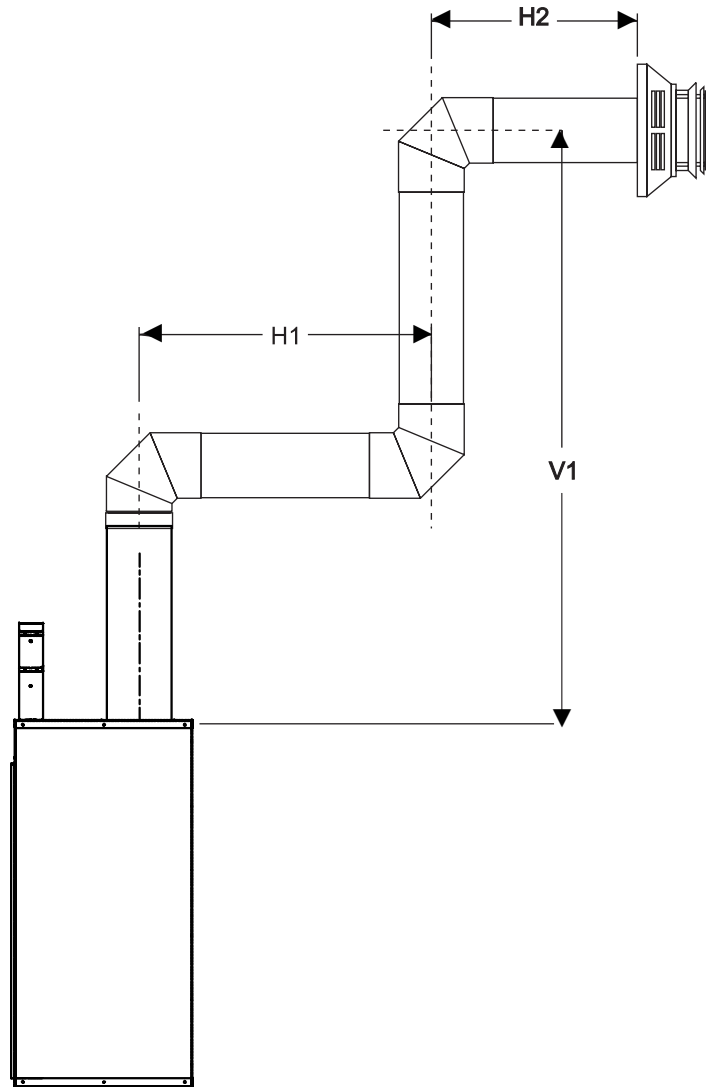

EXAMPLE

If total horizontal needs to be 10', then the minimum required vertical is 6'.

$$H=10' (90^\circ + 90^\circ) = 16' \text{ (equivalent horizontal)}$$

From the graph the required vertical is 7'.

Figure 31- (DV(LT,TT)42)

EXAMPLES - VENT RUN

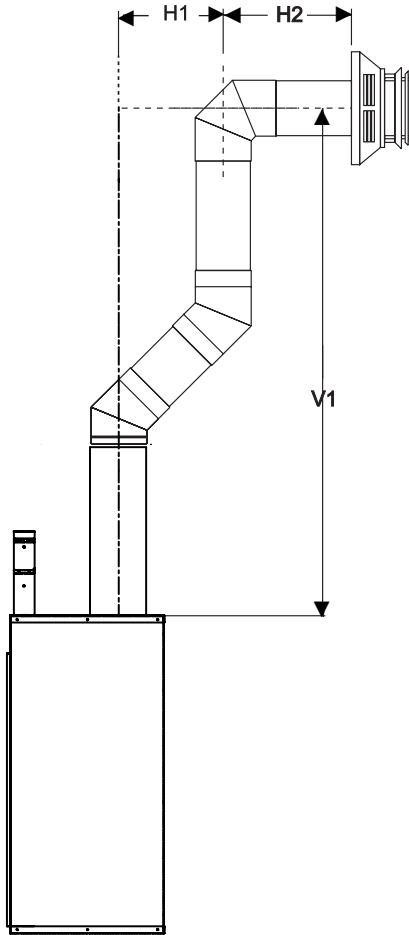

EXAMPLE

If total vertical is to be 9', then the maximum required horizontal run can be 14'

$H=20' - (45^\circ + 45^\circ) = 14'$ (equivalent horizontal)

From the graph the required vertical is 14'.

Figure 32 - (DV(LT,TT)42)

TERMINATION CLEARANCES

Termination clearance for buildings with combustible and noncombustible exteriors.

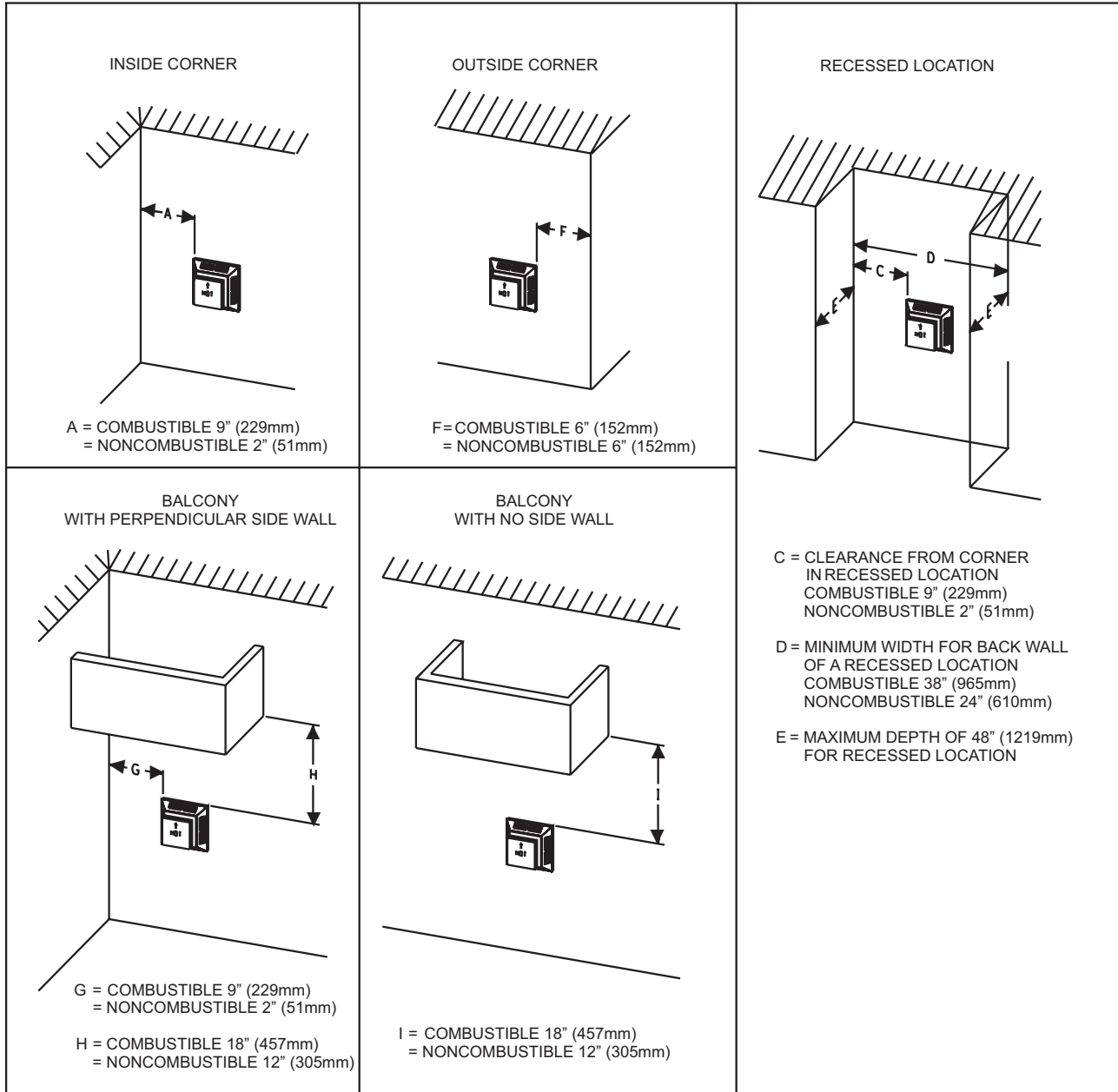

Figure 33

Vertical Sidewall Installations

Important! Minimum clearance between vent pipes and combustible materials is 3 inch (76 mm) on top, and 1 inch (25 mm) on bottom and sides.

Important! When vent termination exits through foundation less than 20 inch (508 mm) below siding outcrop, the vent pipe must extend outward so that the horizontal vent termination is located flush to, or beyond the outcrop siding.

Information on Various Venting Routes and Components

Important: It is always best to locate the fireplace in such a way that minimizes the number of offsets and horizontal vent length.

Since it is very important that the venting system maintain its balance between the combustion air intake and the flue gas exhaust, certain limitations as to vent configurations apply and must be strictly adhered to.

The graph showing the relationship between vertical and horizontal side wall venting will help to determine the various vent lengths allowable.

The horizontal vent run refers to the total length of vent pipe from the flue collar of the fireplace to the face of the outer wall.

Venting termination shall not be recessed into wall or siding.

ATTENTION: Vinyl Soffit, Vinyl Ceiling, Vinyl Overhang Disclaimer

Clearances are to heat resistant material (i.e. wood, metal). This does not include vinyl. Empire Comfort Systems Inc. will not be held responsible for heat damage caused from terminating under vinyl overhangs, vinyl ceilings or vinyl ventilated/unventilated soffits.

VENT TERMINATION CLEARANCES

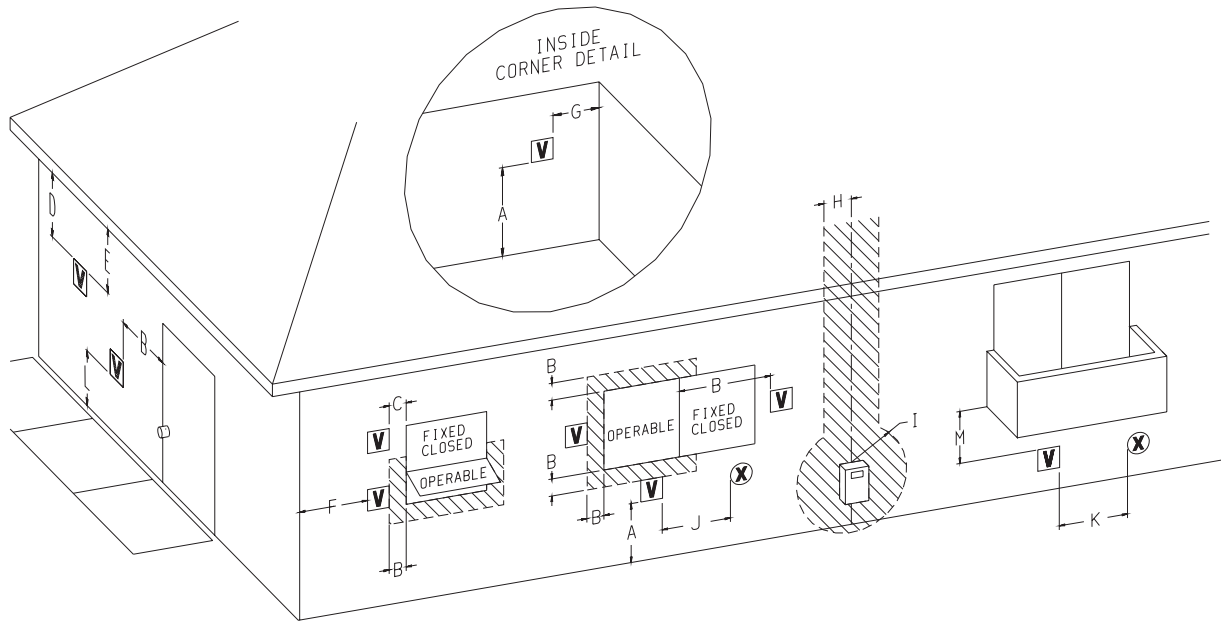

V VENT TERMINAL

X AIR SUPPLY INLET

AREA WHERE TERMINAL IS NOT PERMITTED

	Canadian Installations ¹	US Installations ²		Canadian Installations ¹	US Installations ²
A= Clearance above grade, veranda, porch, deck, or balcony	12 in (30 cm)	12 in (30cm)	I= Clearance to service regulator vent outlet	3 ft (91 cm)	*
B= Clearance to window or door that may be open	6 in (15 cm) for appliances ≤ 10,000 Btuh (3 kW), 12 in (30 cm) for appliances > 10,000 Btuh (3 kW) and ≤ 100,000 Btuh (30 kW), 36 in (91 cm) for appliances > 100,000 Btuh (30 kW)	6 in (15 cm) for appliances ≤ 10,000 Btuh (3 kW), 9 in (23 cm) for appliances > 10,000 Btuh (3 kW) and ≤ 50,000 Btuh (15 kW), 12 in (30 cm) for appliances > 50,000 Btuh (15 kW)	J= Clearance to nonmechanical air supply inlet to building or the combustion air inlet to any other appliance	6 in (15 cm) for appliances ≤ 10,000 Btuh (3 kW), 12 in (30 cm) for appliances > 10,000 Btuh (3 kW) and ≤ 100,000 Btuh (30 kW), 36 in (91 cm) for appliances > 100,000 Btuh (30 kW)	6 in (15 cm) for appliances ≤ 10,000 Btuh (3 kW), 9 in (23 cm) for appliances > 10,000 Btuh (3 kW) and ≤ 50,000 Btuh (15 kW), 12 in (30 cm) for appliances > 50,000 Btuh (15 kW)
C= Clearance to permanently closed window	12 in (30 cm) minimum (recommended to prevent condensation on window)	12 in (30 cm) minimum (recommended to prevent condensation on window)	K= Clearance to a mechanical air supply inlet	6 ft (1.83 m)	3 ft (91 cm) above if within 10 ft (3 m) horizontally
D= Vertical clearance ventilated soffit located above the terminal within a horizontal distance of 2 feet (61 cm) from the center line of the terminal	18 in (46 cm) minimum	18 in (46 cm) minimum	L= Clearance above paved sidewalk or paved driveway located on public property	7 ft (2.13 m) †	*
E= Clearance to unventilated soffit	12 in (30cm) minimum	12 in (30cm) minimum	M= Clearance under veranda, porch deck, or balcony	12 in (30 cm) ‡	*
F= Clearance to outside corner	See Page 20	See Page 20	1 In accordance with the current CSA B149.1, Natural Gas and Propane Installation Code		
G= Clearance inside corner	See Page 20	See Page 20	2 In Accordance with the current ANZI Z223.1/NFPA 54, National Fuel Gas Code		
H= Clearance to each side of center line extended above meter/regulator assembly	3 ft (91 cm) within a height 15 ft (4.5 m) above the meter/regulator assembly	*	† A vent shall not terminate directly above a sidewalk or paved driveway that is located between two single family dwellings and serves both dwellings		

ATTENTION: Vinyl Soffit, Vinyl Ceiling, Vinyl Overhang Disclaimer

Clearances are to heat resistant material (i.e. wood, metal). This does not include vinyl. Empire Comfort Systems Inc. will not be held responsible for heat damage caused from terminating under vinyl overhangs, vinyl ceilings or vinyl ventilated/unventilated soffits.

‡ Permitted only if veranda,, porch, deck, or balcony is fully open on a minimum of two sides beneath the floor.

* For clearances not specified in ANZI Z223.1/NFPA 54 or CSA B149.1, one of the following shall be indicated:

a) A minimum clearance value determined by testing in accordance with Z21.88, or;

b) A reference to the following footnote: "Clearance in accordance with local installation codes and the requirements of the gas supplier."

VENT SYSTEM IDENTIFICATION

Installing Vent Components

Begin the vent system installation by installing the first Simpson Duravent component, 90° elbow to the starting collars or straight pipe on the top of the appliance, then the straight pipe length and then horizontal or vertical termination kit.

Notice: All outer connection joints must be sealed with aluminum tape, screws or silicone sealant rated above 300°F/149°C. The inner flue joints do not require any sealant.

Simpson Duravent vent system components lock into place by sliding the concentric pipe section with four equally spaced interior beads onto the appliance collar or previously installed component end with four equally spaced indented sections. When the internal beads of each starting outer pipe line up, rotate pipe section clockwise 90° (approximately 3 inches). The vent pipe is now locked together.

Continue adding components per the pre-planned vent system configuration. Be certain that each succeeding vent component is securely fitted and locked into the preceding component in the vent system.

The following vent systems are acceptable for use with the DV(LT,TT)(36,42) series fireplaces:

- Simpson Duravent® GS 5" - 8"
- American Metal Products 5" - 8"
- Selkirk Direct-Temp® 5" - 8"
- Security Secure Vent® 5" - 8"

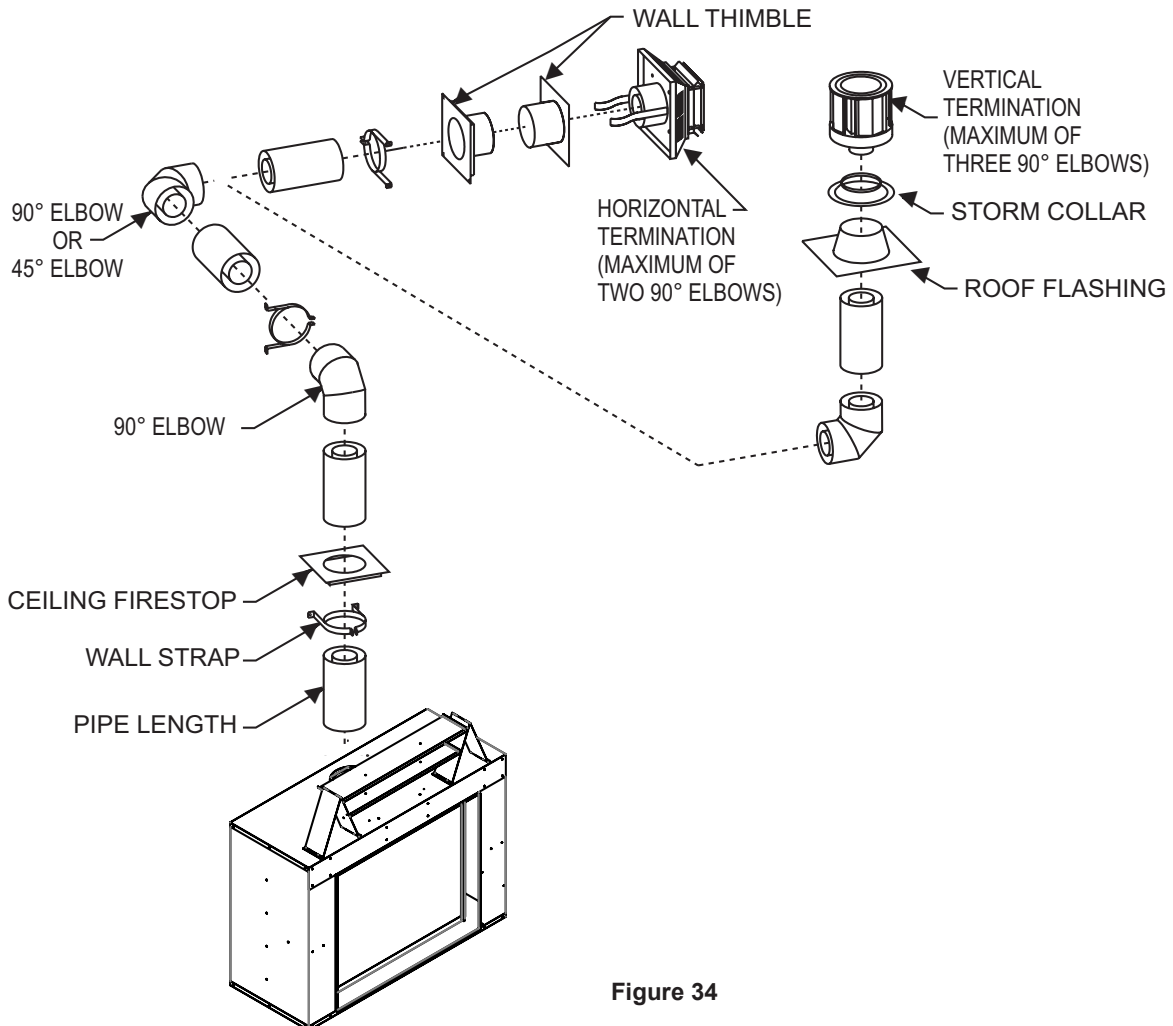

Figure 34

VENTING FRAMING AND FINISHING

Installing Support Brackets

A horizontal pipe support **MUST BE** used for each 3 feet of horizontal run. The pipe supports should be placed around the pipe and nailed in place to framing members. There **MUST BE** a 3 inch clearance to combustibles above flue pipe and elbows and 1 inch clearance on both sides and bottom of the flue pipe to combustibles on all horizontal pipe sections and elbows.

Vertical runs of this vent systems must be supported every 4 feet above the appliance flue outlet by wall brackets attached to the vent pipe and secured with nails or screws to structural framing members.

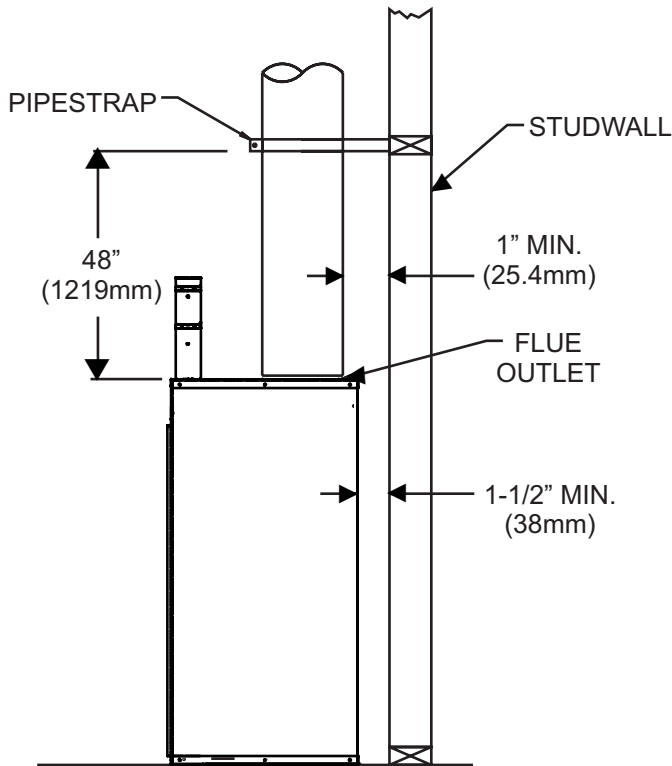

Figure 35

Installing Firestops

Firestops are required for safety whenever the vent system passes through an interior wall, an exterior wall, or a ceiling. These firestops act as a firebreak heat shield and as a means to insure that minimum clearances are maintained to the vent system.

Horizontal runs in the vent system which pass through either interior or exterior walls, require the use of wall firestops on both sides of the wall through which the vent passes.

Cut an appropriate sized hole in wall. **See Figure 36.** Position firestop on interior side of wall for hole.

Attention: Wall firestop hole is off-set towards bottom of wall opening. Secure with nails or screws. Continue the vent run through the firestop. **See Figure 36.**

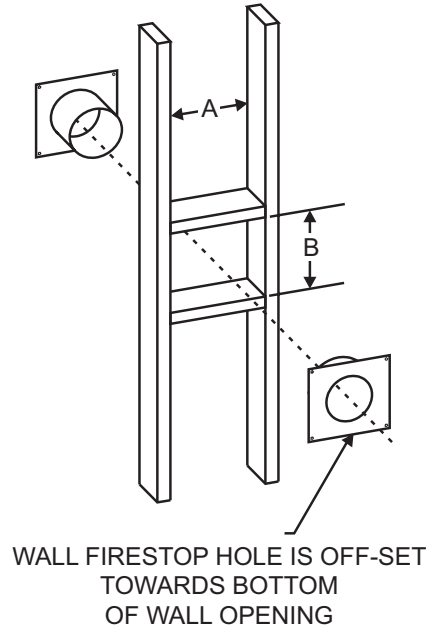

WALL FIRESTOP HOLE IS OFF-SET TOWARDS BOTTOM OF WALL OPENING

Vent Size	A	B
8"	10 3/8"	12 3/8"

Figure 36

Vertical runs of this system which pass through ceilings require the use of one ceiling firestop at the hole in each ceiling through which the vent passes.

Position a plumb bob directly over the center of the vertical vent component and mark the ceiling to establish the center point of the vent. Drill a hole or drive a nail through this center point and check the floor above for any obstructions such as wiring or plumbing runs. Reposition the appliance and vent system, if necessary, to accommodate ceiling joists and/or obstructions.

Cut an appropriate sized hole through the ceiling, using the center point previously marked. **See Figure 37.** Frame the hole with framing lumber the same size as the ceiling joists. **See Figure 37.**

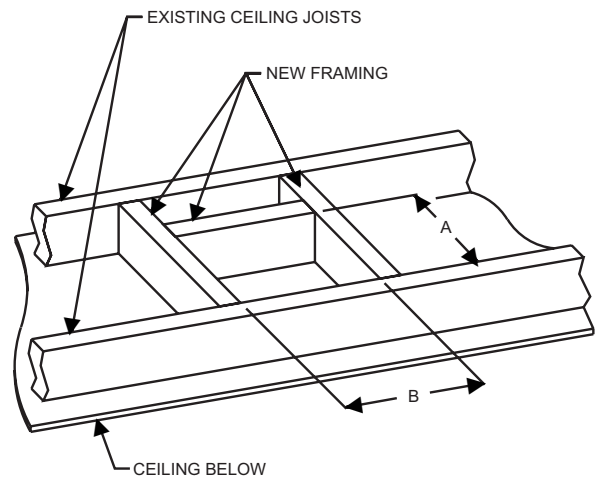

Vent Size	A	B
8"	10 1/2"	10 1/2"

Figure 37

VENTING FRAMING AND FINISHING (continued)

Installing Support Brackets

Install a horizontal pipe support used for each 3 feet of horizontal run to framing members. Allow 3 inches of clearance to combustibles above 8 inch diameter pipe and elbows and 1 inches of clearance on both sides and bottom.

Support vertical runs of this vent systems every 4 feet using wall brackets attached to the vent pipe and secured with nails or screws to structural framing.

Note: Maintain all clearances to combustibles as shown in **Figures 1 to 4** on page 7.

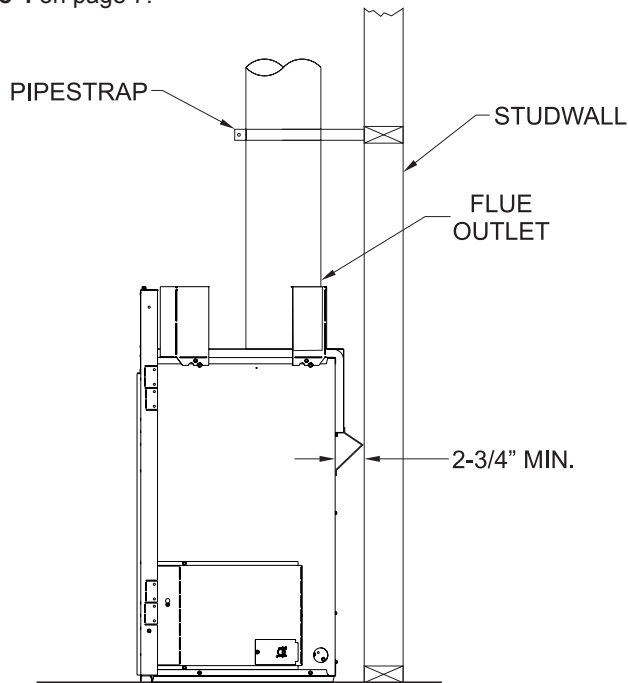

Figure 45

Installing Firestops

Firestops are required for safety whenever the vent system passes through an interior wall, an exterior wall, or a ceiling. These firestops act as a firebreak heat shield and as a means to insure that minimum clearances are maintained to the vent system.

Horizontal Firestops

Horizontal runs in the vent system which pass through either interior or exterior walls, require the use of wall firestops on both sides of the wall through which the vent passes.

Position the firestops on both sides of the framed hole, previously cut. Refer to **Figure 39** for sizing information. Secure firestop with nails or screws. The heat shields of the firestops **MUST BE** placed towards the top of the hole. Continue the vent run through the firestops.

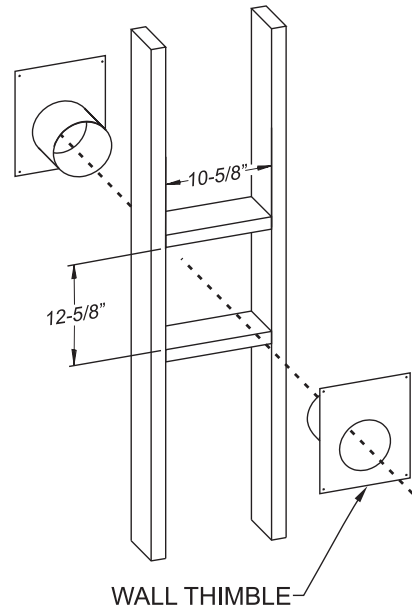

Figure 39

NOTE: SD58DVAWTEC Wall thimble is necessary to maintain the required three inches of clearance to combustibles above the vent. Framed hole dimensions shown above are for this wall thimble.

VENTING FRAMING AND FINISHING (continued)

If the area above the ceiling is NOT an attic, position and secure the ceiling firestop on the ceiling side of the previously cut and framed hole. **See Figure 40.** If the area above the ceiling is an attic, position and secure the firestop on top of the previously framed hole. **See Figure 41.**

Notice: Remove insulation from the framed area in the attic before installing the firestop and/or vent pipes.

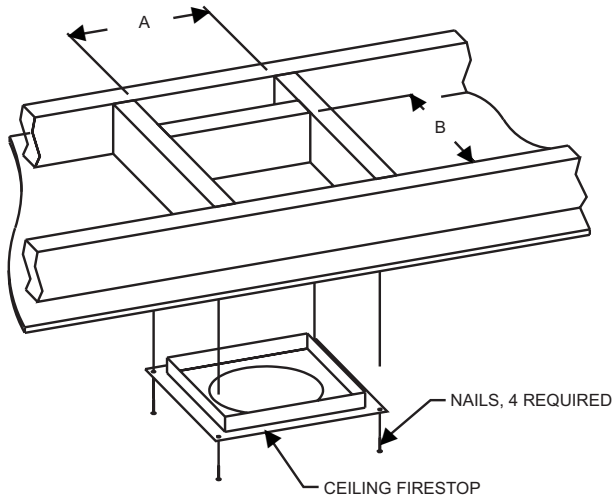

Vent Size	A	B
8"	10 1/2"	10 1/2"

Figure 40

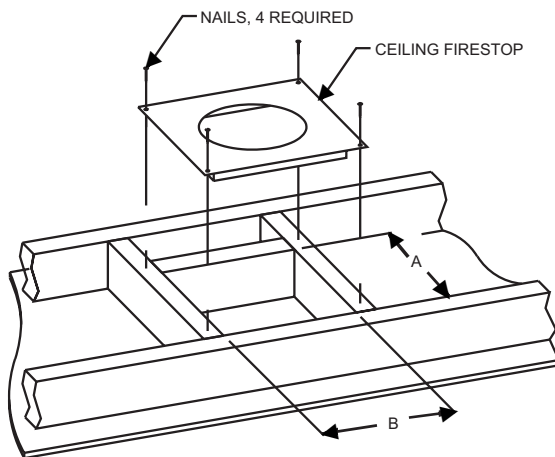

Vent Size	A	B
8"	10 1/2"	10 1/2"

Figure 41

See **Horizontal Termination** Page 26 and **Vertical Termination** Pages 27 and 28.

HORIZONTAL TERMINATION

Notice: Termination cap should pass through the wall firestop from the exterior of the building. Adjust the termination cap to its final exterior position on the building.

⚠ WARNING

Termination cap must be positioned so that arrow is pointing up.

Attach the termination cap with the four wood screws provided. Before attachment of the termination, run a bead of silicone sealant rated above 250°F on its outside edge too, so as to make a seal to the exterior wall.

Notice: Wood screws can and should be replaced with appropriate fasteners for use on stucco, brick, concrete or other types of siding.

⚠ CAUTION

If exterior walls are finished with vinyl siding, (or materials that could become discolored or warp) it is necessary to install a vinyl siding standoff.

The vinyl siding standoff will be installed between the vent termination and the exterior wall. **See Figure 42.** This horizontal vent termination bolts onto the flat portion of the vinyl siding standoff, so an air space will exist between the wall and the termination cap.

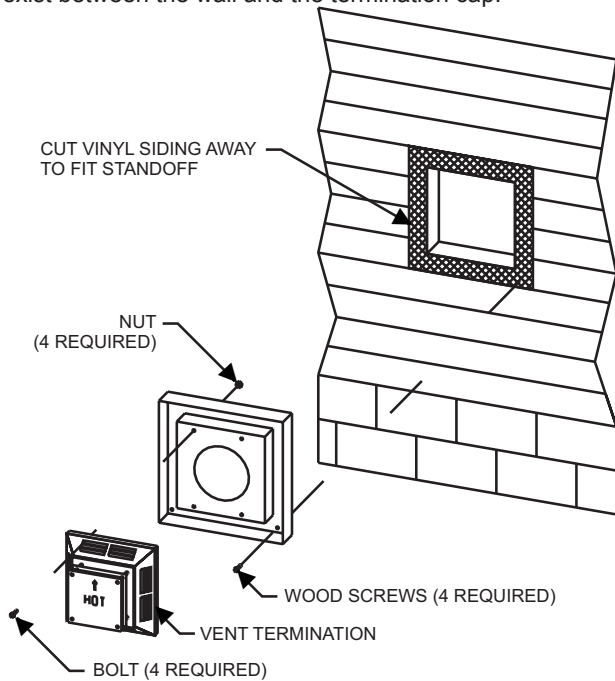

Figure 42

Locate and mark the center point of the venting pipe. Using a nail on the underside of the roof and drive this nail through this center point. Make the outline of the roof hole around this center point.

Notice: Size of the roof hole dimensions depend on the pitch of the roof. There must be a 1 inch clearance (25mm) to the vertical pipe sections. This clearance is to all combustible material.

Cover the opening of the vent pipe and cut and frame the roof hole. Use framing lumber the same size as the roof rafters and install the frame securely. Flashing anchored to frame must withstand high winds. The storm collar is placed over this joint to make a water-tight seal. Non-hardening sealant should be used to completely seal this flashing installation.

Determining Minimum Vent Height Above the Roof.

⚠ WARNING

Major U.S. building codes specify minimum chimney and/or vent height above the roof top. These minimum heights are necessary in the interest of safety. These specifications are summarized in Figure 43.

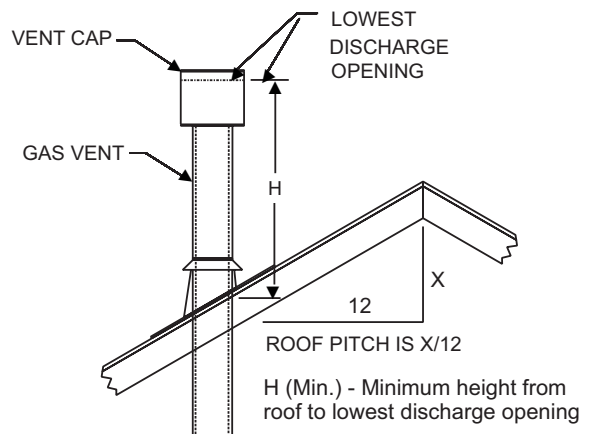

ROOF PITCH	H (Min.)
Flat to 6/12	12" (305 mm)
6/12 to 7/12	15" (381 mm)
Over 7/12 to 8/12	18" (457 mm)
Over 8/12 to 16/12	24" (610 mm)
Over 16/12 to 21/12	36" (914 mm)

Figure 43

Note that for steep roof pitches, the vent height must be increased. In high wind conditions, nearby trees, adjoining roof lines, steep pitched roofs, and other similar factors can result in poor draft, or down-drafting. In these cases, increasing the vent height may solve this problem.

VERTICAL TERMINATION

When terminating the vent cap near an exterior wall or overhang, maintain minimum clearances as shown in **Figure 44**.

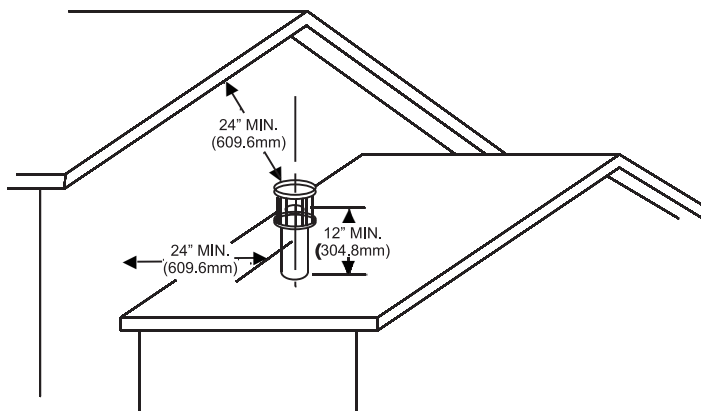

Figure 44

General Maintenance

Conduct an inspection of the venting system semi-annually. Recommended areas to inspect are as follows:

1. Check areas of the venting system which are exposed to the elements for corrosion. These will appear as rust spots or streaks and, in extreme cases, holes. These components should be immediately replaced.
2. Remove the cap and shine a flashlight down the vent. Remove any bird nests or other foreign material.
3. Check for evidence of excessive condensate, such as water droplets forming in the inner liner and subsequently dripping out at joints. Condensate can cause corrosion of caps, pipe and fittings. It may be caused by having excessive lateral runs, too many elbows and exterior portions of the system being exposed to cold weather.
4. Inspect joints to verify that no pipe sections or fittings have been disturbed and, consequently, loosened. Also, check mechanical supports, such as wall straps or plumbers' tape for rigidity.

Venting terminal shall not be recessed into a wall or siding.

A removable panel or other means must be provided in the enclosure for visual inspection of the flue connection.

NOTE: This also pertains to vertical vent systems installed on the outside of the building.

Slide the vertical vent cap over the ends of the vent pipe and secure. **See Figure 44.**

Installing the Vent System in a Chase

A chase is a vertical box-like structure built to enclose the gas appliance and/or its vent system. Vertical vent runs on the outside of a building may be, but are not required to be installed inside a chase.

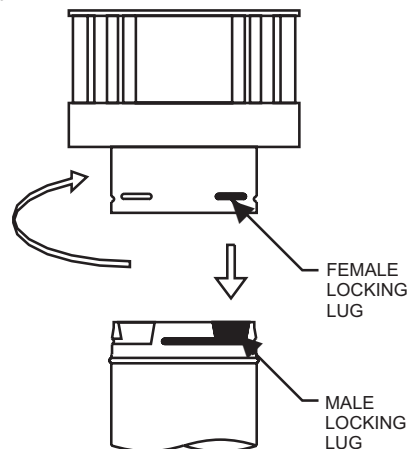

Figure 45

CAUTION: Treatment of firestop spacers and construction of the chase may vary with the type of building. These instructions are not substitutes for the requirements of local building codes. Therefore, your local building codes must be checked to determine the requirements for these steps.

NOTE: When installing this vent system in a chase, it is always good building practice to insulate the chase as you would the outside walls of your home. This is especially important for cold climate installations. Upon completion of building your chase framing, install the vent system by following the instructions in this manual. Remember to build the chase large enough so that minimum clearance of combustible materials (including insulation) to the vent system are maintained.

Reassembly and Resealing Vent Pipe System

Attach vent pipe to inlet and outlet vent adaptor on fireplace, replace horizontal and vertical pipe lengths, elbows and horizontal or vertical termination kit.

All vent system components lock into place by sliding the concentric pipe section with four equally spaced interior beads onto the appliance collar or previously installed component end with four equally spaced indented sections. When the internal beads of each starting outer pipe line up, rotate pipe section clockwise 90° (approximately 3 inches). The vent pipe is now locked together.

VERTICAL TERMINATION (continued)

Continue replacing components per the vent system configuration. Be certain that each succeeding vent component is securely fitted and locked into the preceding component in the vent system.

Reassembly and Resealing Gas Accumulation Relief System Glass Frame Assembly and Combustion Chamber

Whenever the glass frame assembly is pivoted open by a delayed ignition in the main burner, the glass frame assembly gaskets and combustion chamber must be examined by a qualified service person for damage. All damaged gaskets on the glass frame assembly and combustion chamber must be replaced by a qualified service person. If damage occurs to the combustion chamber, it must be replaced by a qualified service person. Contact Empire Comfort Systems, Inc. for replacement parts.

Vertical Through the Roof Applications

Your Gas Fireplace has been approved for:

- Vertical installations up to 40 feet in height.
- Two sets of 45 degree elbow offsets within these vertical installations. From 0 to a maximum of 8 ft. a vent pipe can be used between elbows.
- Wall straps must be used to support offset pipe every 4'.

This application will require that you first determine the roof pitch and use the appropriate venting components.

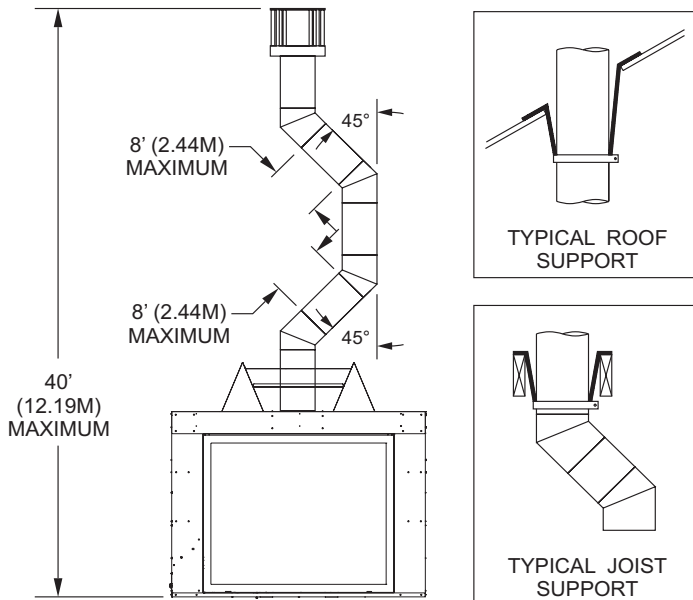

Figure 46

Vertical Vent Baffle Installation

In applications without elbows (a straight vertical installation), the use of a vertical vent baffle may be required. The vertical vent baffle is the flat piece of painted steel with eight holes located in the instruction envelope.

- Locate and remove the two screws to the right of the flue opening.
- Verify the flue blockage requirements to steady the flame. **Note:** 40 foot vertical requires maximum blockage. 10 foot vertical requires minimum blockage.
- Align vertical vent baffle holes with the holes in the firebox top and secure vent baffle with the two screws in the same holes they were removed from in step 1.

DVTT36 LOG IDENTIFICATION



Part Number 29364 - Right Ember Bed Chunk (A)



Part Number 31077 - Left Ember Chunk with pin (I)



Part Number 29135 - Left Ember Bed Chunk (B)



Part Number 29127 - Left Branch (J)



Part Number 29133 - Ember Bed Front (C)



Part Number 29128 - Center Branch (K)



Part Number 29122 - Left Rear Log (E)



Part Number 29129 - Right Branch (L)



Part Number 31078 - Center Ember Chunk (H)



Part Number 29130 - Right Top Branch (M)

DVTT36 LOG PLACEMENT

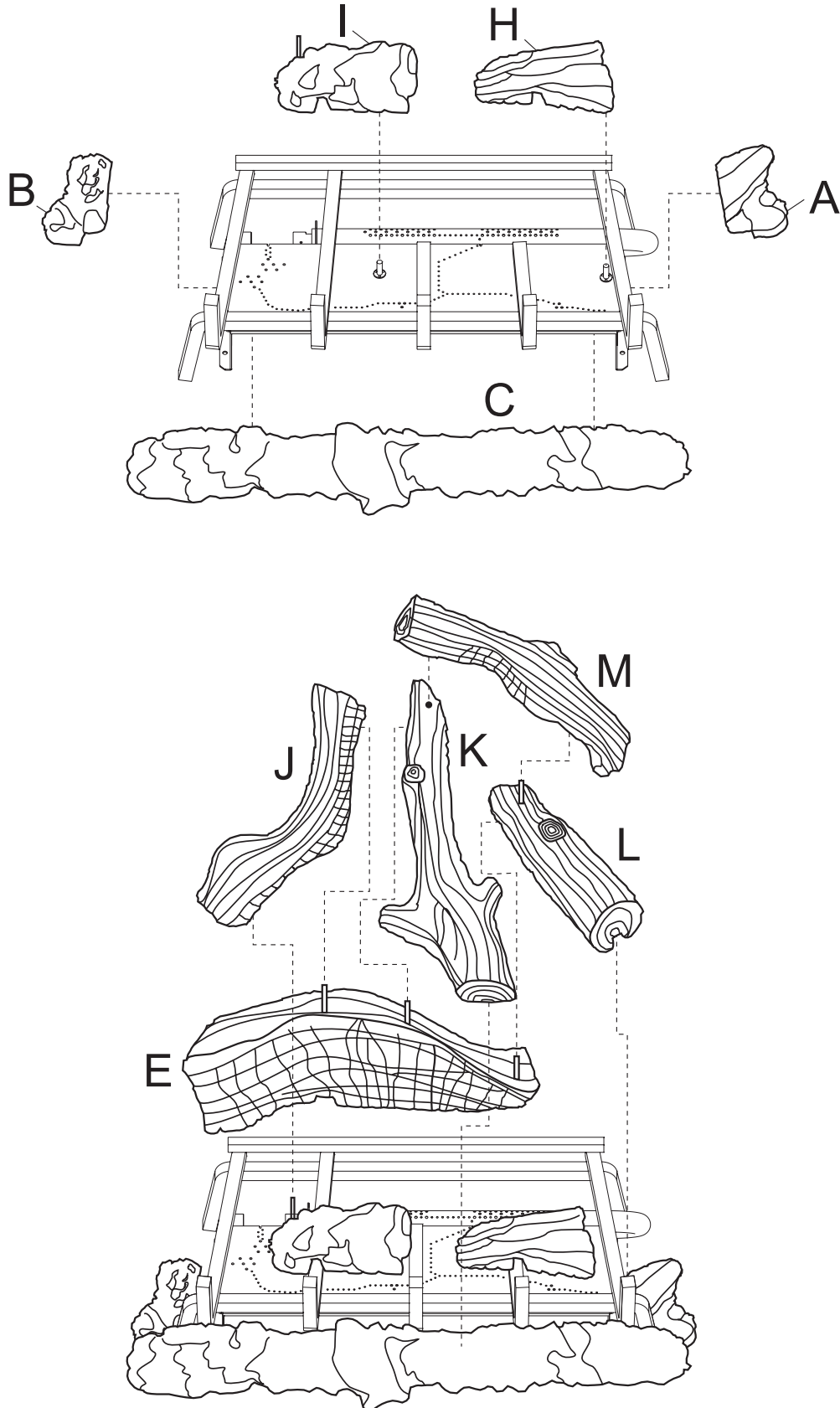

Figure 47 - 36" BOTTOM LOG PLACEMENT

DVTT36 LOG PLACEMENT

Before you begin: If you are installing logs into the DVTT36 Model then this fireplace is supplied with a set of 10 ceramic fiber logs. Do not handle these logs with your bare hands. Always wear gloves to prevent skin irritation from ceramic fibers. After handling logs, wash your hands gently with soap and water to remove any traces of fiber. The positioning of logs is critical to safe and clean operation of this fireplace. Sooting and other problems may result if the logs are not properly and firmly positioned in the fireplace.

1. Remove mesh screen if applicable.
2. Remove glass door from firebox.
3. Remove logs from bun.
4. Remove the plastic wire tie holding the grate to the burner. Discard the plastic wire tie and set the grate aside.
5. Place liner bottom into firebox.



6. Place log grate into firebox. The front bar will butt-up against the burner.

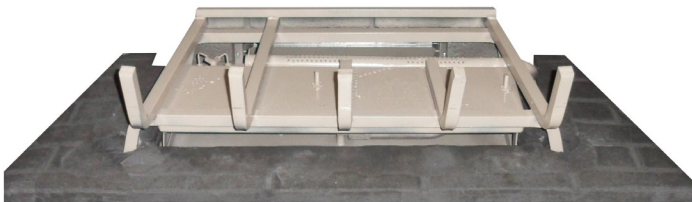

7. Place the Right Ember Bed Chunk (A) between the right front and right rear legs of the log grate and resting on the liner bottom.

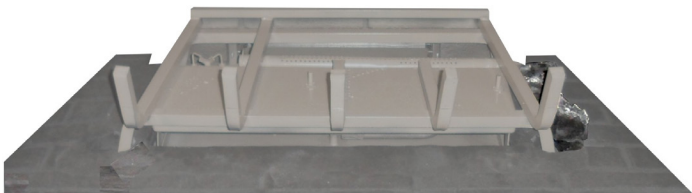

8. Place the Left Ember Bed Chunk (B) between the left front and rear legs of the log grate and resting on the liner bottom.

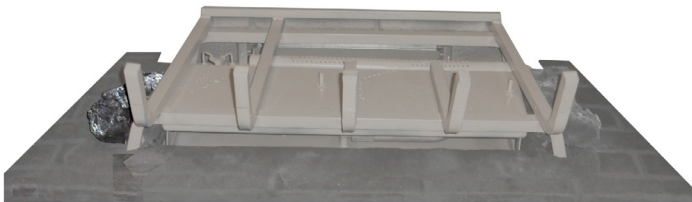

9. Slide the Ember Bed Front (C) under the log grate. It will be in front of the Left Ember Chunk (B) leaving an open space to the right front of the log grate.

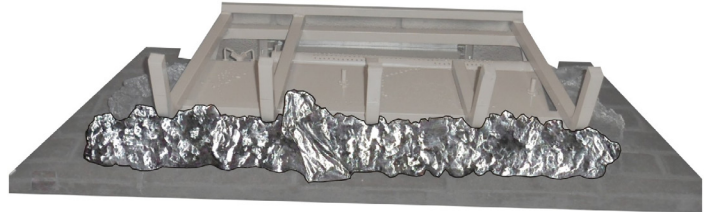

10. Place the Left Rear Log (E) on the rear bar of the log grate. The slot and groove on the log will fit over the left two bars of the log grate.



11. Place the Center Ember Chunk (H) onto the middle pin on the burner and over the middle right bar of the log grate.

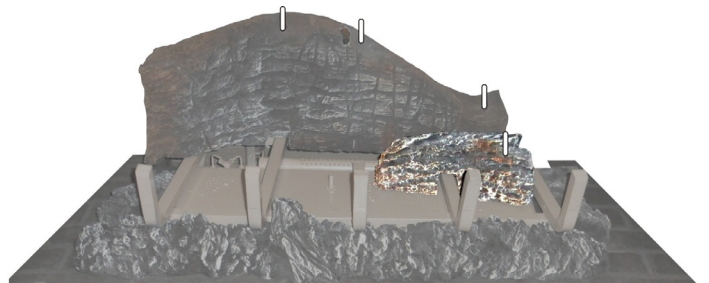

12. Place the Left Ember Chunk (I) on the left pin and over the second log grate burner bar from the left and partially of the middle left bar.

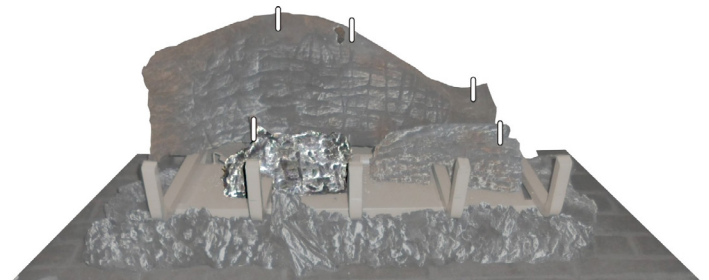

DVTT36 LOG PLACEMENT

13. Place the Left Branch (J) on the left pin of the Left Rear Log (E) and the pin on the Left Ember Burner Chunk. The end of the log will rest on the left log grate bar.

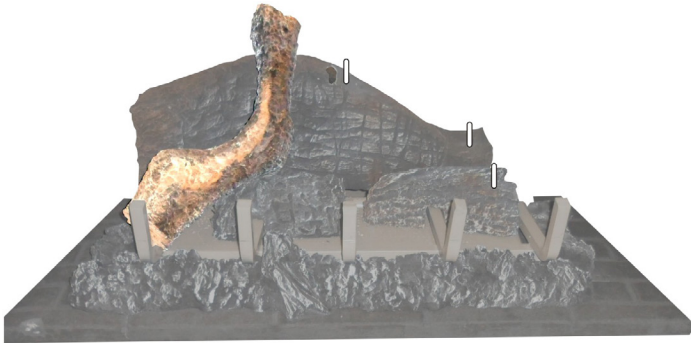

16. Place the Right Top Branch (M) on the pins on the Center Branch (K) and on the Right Branch (L).



14. Place the Center Branch (K) between the two middle log grate bars on the middle pin on the Left Rear Log (E).

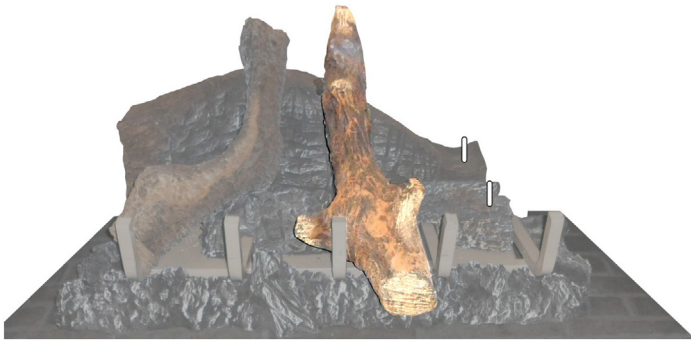

17. After all logs are properly positioned, place small "dime size" pieces of Rockwool (ember material) in the shaded area on the burner as shown in Figure 48.

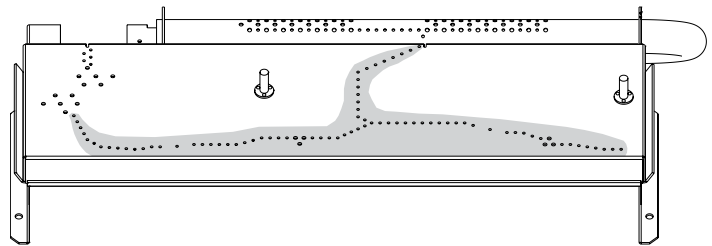

**Ember Placement - 36" Burner
Figure 48**

15. Place the Right Branch (L) onto the right pin on the Left Rear Log (E) and the top of the Center Ember Chunk (H). The end of the log will "float" and touch the log grate bar on the right.



DVTT42 LOG IDENTIFICATION



Part Number 29131 - Right Ember Bed Chunk (A)



Part Number 29125 - Middle Ember Chunk (H)



Part Number 29135 - Left Ember Bed Chunk (B)



Part Number 29124 - Left Ember Chunk (I)



Part Number 29133 - Ember Bed Front (C)



Part Number 29127 - Left Branch (J)



Part Number 29134 - Ember Bed Front Extension (D)



Part Number 29128 - Center Branch (K)



Part Number 29122 - Left Rear Log (E)



Part Number 29129 - Right Branch (L)



Part Number 29123 - Right Rear Log (F)



Part Number 29130 - Right Top Branch (M)



Part Number 29126 - Right Ember Chunk (G)



Part Number 29332 - Right Log Chunk (N)

DVTT42 LOG PLACEMENT

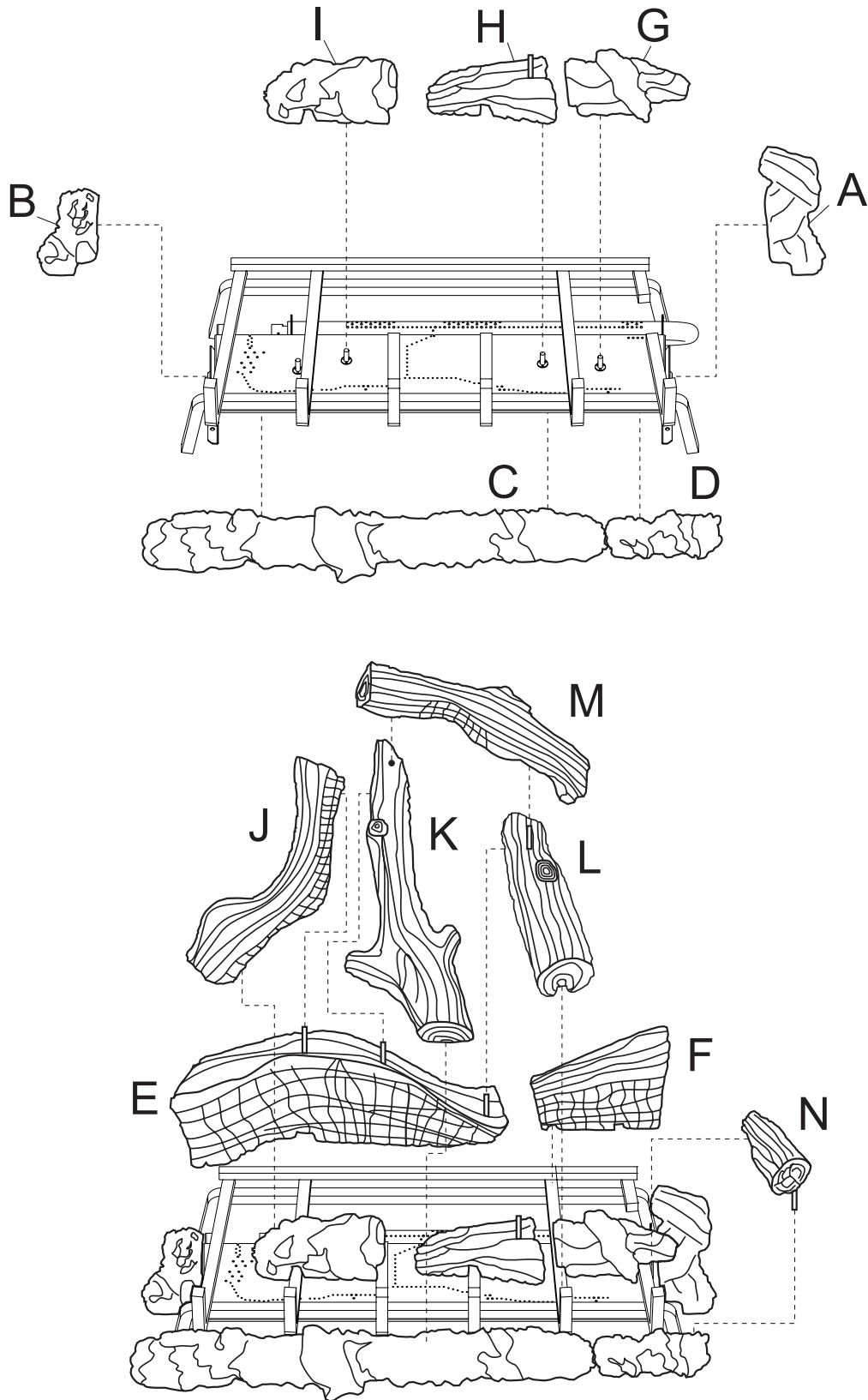

Figure 49 - 42" BOTTOM LOG PLACEMENT

DVTT42 LOG PLACEMENT

Before you begin: If you are installing logs into the DVTT42 model then this fireplace is supplied with a set of 14 ceramic fiber logs. Do not handle these logs with your bare hands. Always wear gloves to prevent skin irritation from ceramic fibers. After handling logs, wash your hands gently with soap and water to remove any traces of fiber. The positioning of logs is critical to safe and clean operation of this fireplace. Sooting and other problems may result if the logs are not properly and firmly positioned in the fireplace.

1. Remove mesh screen if applicable.
2. Remove glass door from firebox.
3. Remove logs from bun.
4. Remove the plastic wire tie holding the grate to the burner. Discard the plastic wire tie and set the grate aside.
5. Place liner into firebox.



6. Place log grate into firebox. The front bar will butt-up against the burner.

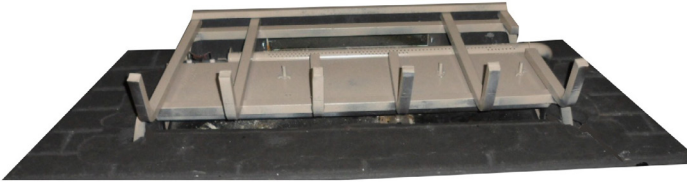

7. Place the Right Ember Bed Chunk (A) between the right front and right rear legs of the log grate and resting on the liner bottom.



8. Place the Left Ember Bed Chunk (B) between the left front and rear legs of the log grate and resting on the liner bottom.

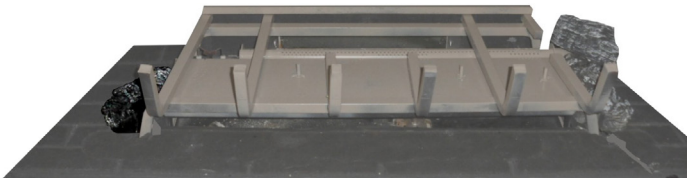

9. Slide the Ember Bed Front (C) under the log grate. It will be in front of the Left Ember Chunk (B) leaving an open space to the right front of the log grate.



10. Place the Ember Bed Front Extension (D) next to the right of the Ember Bed Front and under the log grate.

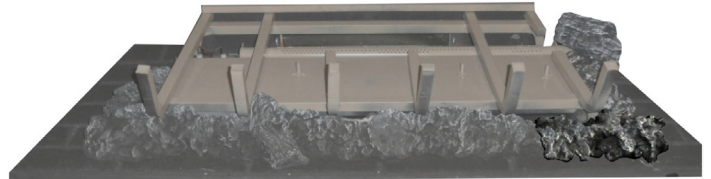

11. Place the Left Rear Log (E) on the rear bar of the log grate. The slot and groove on the log will fit over the left two bars of the log grate.

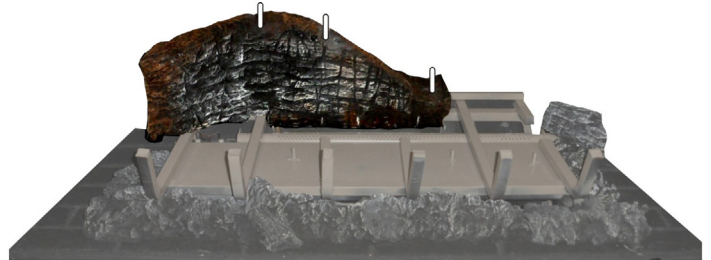

12. Place the Right Rear Log (F) against the back bar of the log grate. The grooves on the log will fit over the two right bars of the log grate.



DVTT42 LOG PLACEMENT

13. Place Right Ember Chunk (G) onto the right pin on the burner and over the two right bars of the log grate.

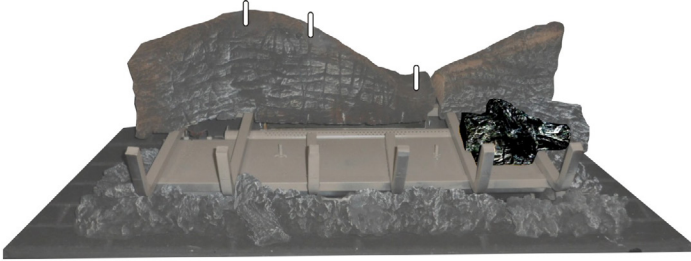

14. Place the Middle Ember Chunk (H) onto the middle pin on the burner and over the middle right bar of the log grate.

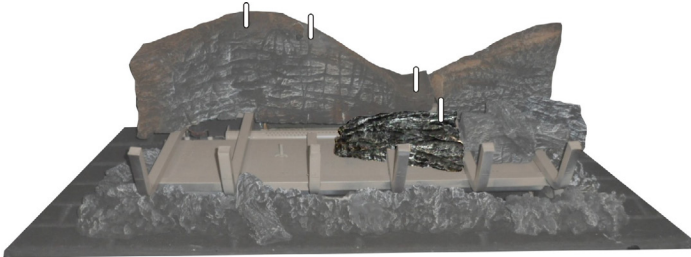

15. Place the Left Ember Chunk (I) on the left pin and over the second log grate burner bar from the left and partially of the middle left bar.

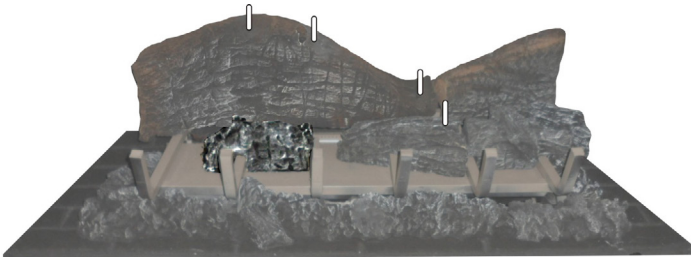

16. Place the Left Branch (J) on the left pin of the Left Rear Log (E) and on top of the Left Ember Burner Chunk. The end of the log will rest on the left log grate bar.

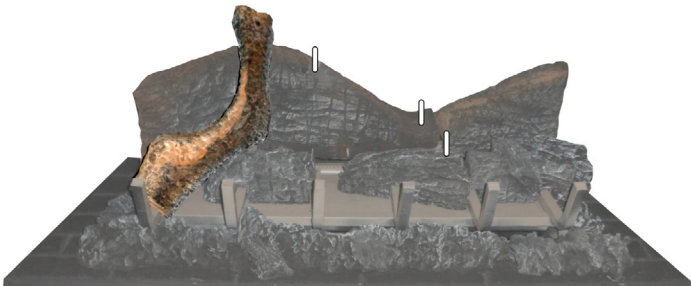

17. Place the Center Branch (K) between the two middle log grate bars on the middle pin on the Left Rear Log (E).

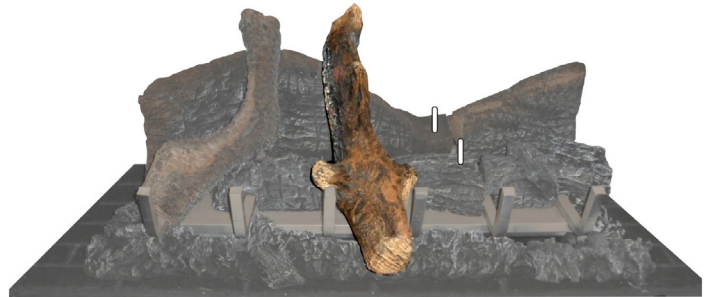

18. Place the Right Branch (L) onto the right pin on the Left Rear Log (E) and the pin on the Middle Ember Chunk (H). The end of the log will touch the log grate bar second from the right.



19. Place the Right Top Branch (M) on the pins on the Center Branch (K) and on the Right Branch (L).



20. Place the Right Log Chunk (N) onto the pin on the Ember Bed Front Extension (D). The Log should point towards the Right Ember Bed Chunk (A).



DVTT42 LOG PLACEMENT

21. After all logs are properly positioned, place small "dime size" pieces of Rockwool (ember material) in the shaded area on the burner as shown in Figure 50.

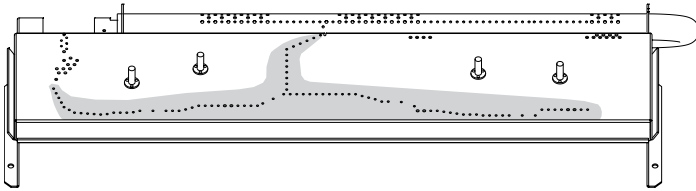

Ember Placement - 42" Burner
Figure 50

DVLT36 AND DVLT42 GLASS MEDIA INSTALLATION

Installation of the glass media is critical to safe and clean operation of the fireplace.

Note: Before installing the glass media, see Accent Lamp Light Replacement section on page 53 of this manual for bulb placement.

1. Remove the mesh screen and the glass frame assembly.
2. Place the pilot guard around the pilot.
3. Place the glass media around the Accent Burner. Fill the media basket until the glass media covers the burner with only one layer of glass. Do not place any of the glass media inside the pilot guard.
4. Remaining glass media should be placed in front of the burner cover for added ambience when accent light is on.

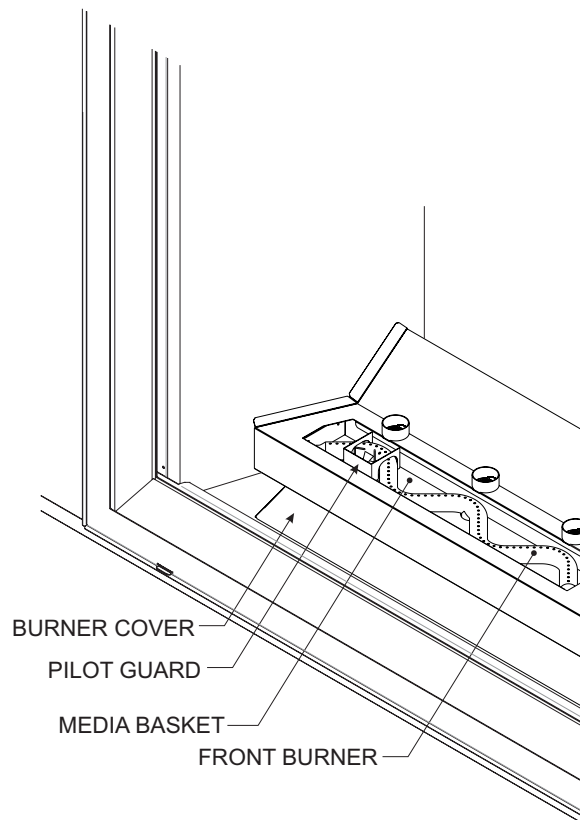

Figure 51

BARRIER INSTALLATION

Note: A barrier is required for operation of the appliance.

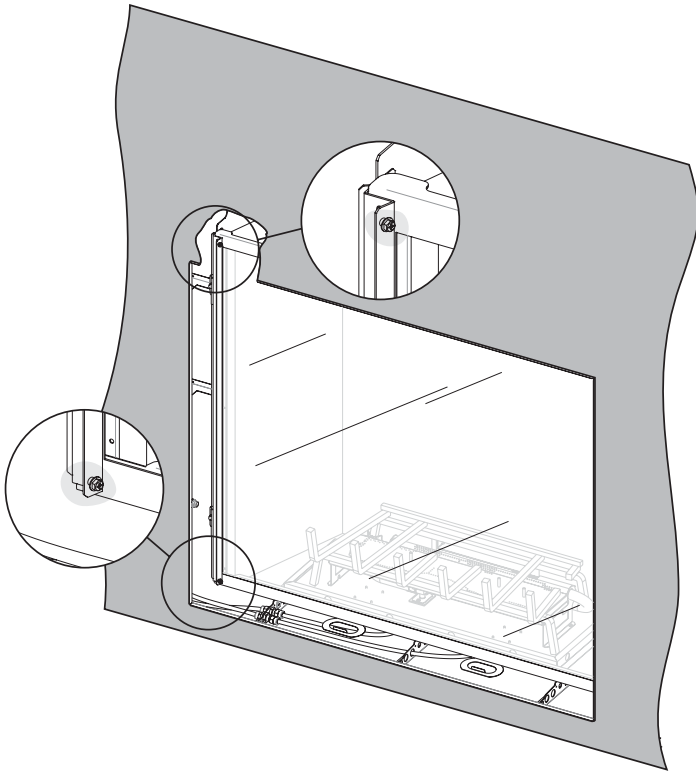

Figure 52

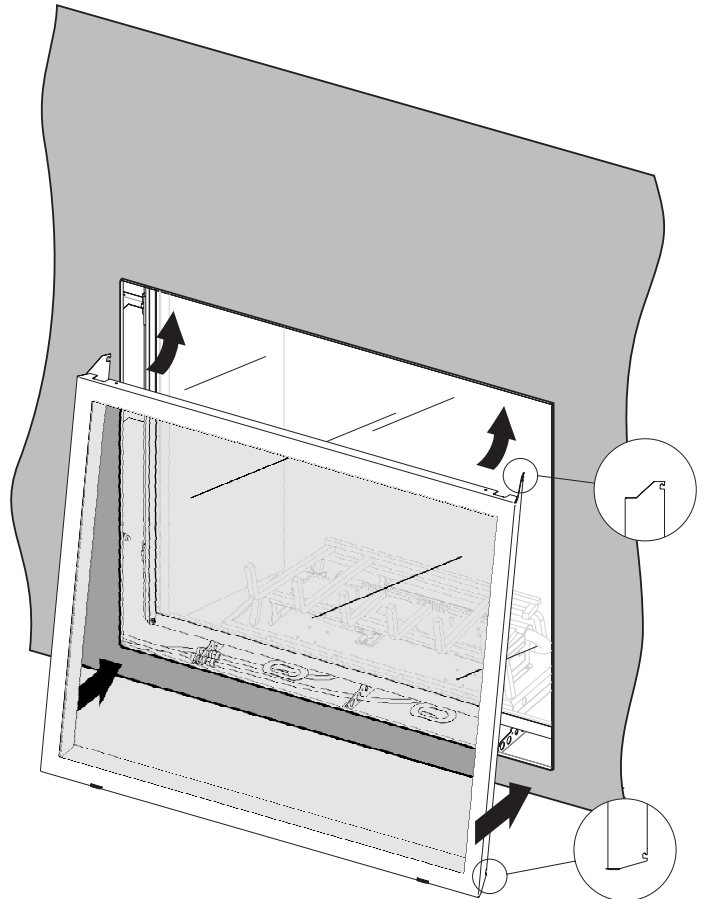

Figure 53

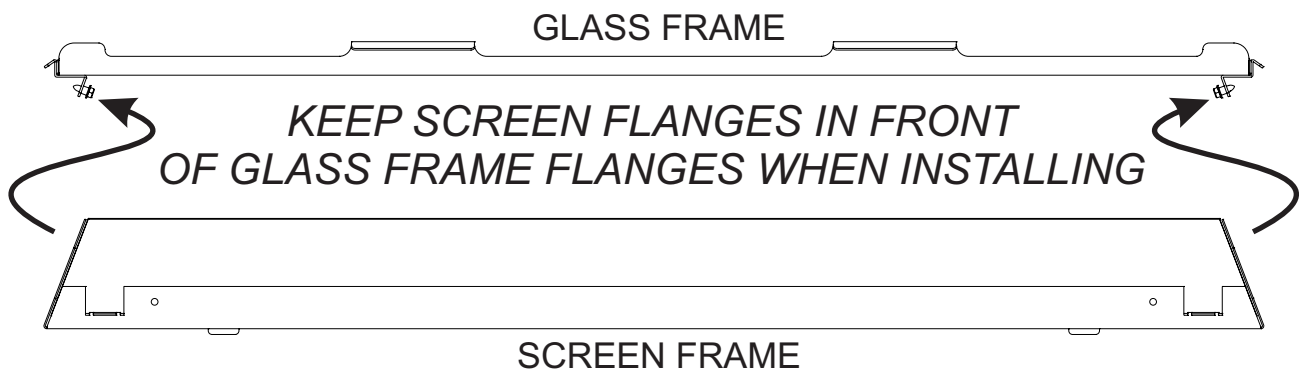

Figure 54



MULTIFUNCTION REMOTE LIGHTING INSTRUCTIONS

FOR YOUR SAFETY READ BEFORE LIGHTING

WARNING: IF YOU DO NOT FOLLOW THESE INSTRUCTIONS EXACTLY, A FIRE OR EXPLOSION MAY RESULT CAUSING PROPERTY DAMAGE, PERSONAL INJURY, OR LOSS OF LIFE.

- A. This appliance has a pilot which must be lighted by hand. When lighting the pilot, follow these instructions exactly.
- B. **BEFORE LIGHTING**, smell around the appliance area for gas. Be sure to smell next to the floor because some gas is heavier than air and will settle on the floor.
- WHAT TO DO IF YOU SMELL GAS**
- Do not try to light any appliance.
 - Do not touch any electrical switch.
 - Do not use any phone in your building.
 - Immediately call your gas supplier from a neighbor's phone. Follow the gas supplier's instructions. If you can not reach your gas supplier, call the fire department.
- C. Use only your hand to push in or turn the gas control
- D. knob. Never use tools. If the knob will not push in or turn by hand, don't try to repair it, call a qualified service technician. Force or attempted repair may result in a fire or explosion.
- D. Do not use this appliance if any part has been under water. Immediately call a qualified service technician to inspect the appliance and to replace any part of the control system and any gas control which has been under water.

LIGHTING INSTRUCTIONS

1. **STOP!** Read the safety information above.
2. Turn OFF electric power to the appliance.
3. Open bottom louver assembly (if applicable).
4. Turn gas cock counterclockwise  to "ON" position.
5. Wait ten minutes to clear out any gas. Then smell for gas, including near the floor. If you smell gas, **STOP!** Follow "B" in the safety information above on this label. If you do not smell gas, go to the next step.
6. Turn ON electric power to the appliance.
7. Find pilot - Follow metal tube from gas control. The pilot is behind the burner on the right side.
8. Using the remote control, turn main flame to "ON." If the pilot does not light within 60 seconds, stop and go to Step 5.
9. Refer to remote control instructions for detailed information, control features, and operation. Note: There is a switch on the side of the Electronic Control Module that allows for a continuous standing pilot mode or an intermittent pilot mode. See appliance manual for location of this switch. If the pilot or burner does not stay lit (in the standing pilot mode), stop and immediately call a qualified service technician or gas supplier.
10. If the burner or pilot does not operate properly after several tries, turn the gas control knob clockwise  to "OFF" and call your service technician or gas supplier.
11. Close bottom louver assembly.
12. Operation of the gas valve, blower, and/or optional light must be controlled by using the hand held remote control. Refer to remote instructions for detailed operation information.

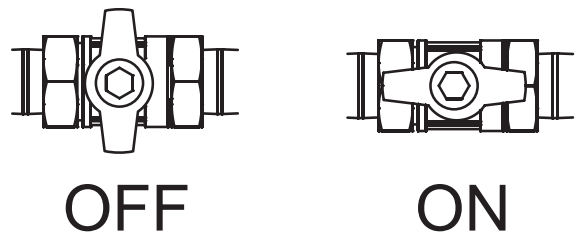
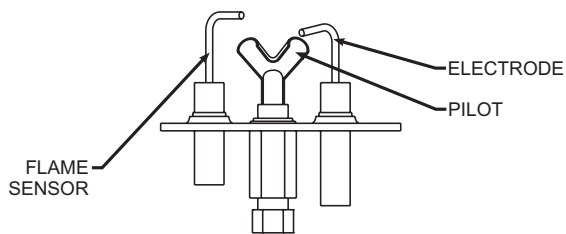

TO TURN OFF GAS TO APPLIANCE

1. Turn off all electric power to the appliance if service is to be performed (if applicable).
2. Open bottom louver assembly.
3. Locate On/Off gas cock and turn clockwise to "OFF." Do not force. 
4. Close bottom louver assembly.

MULTIFUNCTION REMOTE OPERATING INSTRUCTIONS

RF VALVE OPERATION

(AF-4004 Electronic Gas Valve system only)

NOTICE: THE FIREPLACE WILL ONLY OPERATE WITH THE HAND HELD REMOTE TRANSMITTER. THE TRANSMITTER CONTROLS ALL FUNCTIONS OF THE FIREPLACE.

Please refer to the separate instructions for detailed operation and programming of the Multi-function Remote Control.

The AF-4004 Electronic Gas Control Valve features a Remote controlled High/Low Variable - 6 Volt DC Motor Drive. This gas control uses a spark to pilot burner assembly. For use with Propane or natural gas (pre-set at the factory).

This gas control system includes the items identified in **Figure 55**.

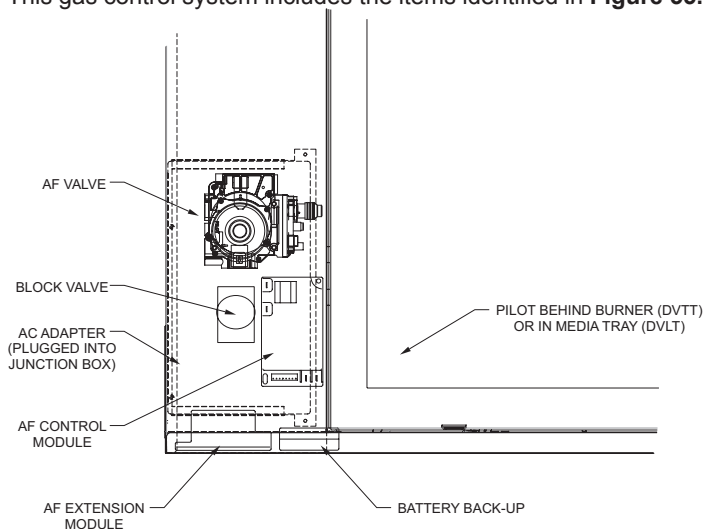

ALL COMPONENTS ARE LOCATED IN THE LOWER LEFT CORNER BEHIND REMOVABLE PANEL

Index No.	Description
1	Battery Back-up
2	AF Valve
3	Block Valve
4	AF Control Module
5	AF Extension Module
6	AC Adapter
7	Pilot Assembly - Nat
	Pilot Assembly - LP

Figure 55

SPECIAL FEATURES ON THE CONTROL MODULE

The Control Module has two special pilot mode features built into the system.

CONTINUOUS PILOT FEATURE: This allows the user to change from a spark to pilot system to a standing pilot system.

1. There is a switch located on the right side of the Control Module (#4) that reads CONTINUOUS PILOT ON/OFF. This switch will allow the user to select the pilot mode of operation.
2. When the continuous pilot switch is in the OFF position and the appliance turned ON, the pilot will spark and light, then the main burner will light as well. When the appliance is turned OFF, the pilot and main burner will shut OFF.

3. When the continuous pilot switch is in the ON position and the appliance is turned ON, the pilot will spark and light. Then when the appliance is turned OFF the pilot will remain ON, but the main burner will shut OFF.

Note: The Continuous pilot mode setting is generally recommended on Direct Vent appliances during cold climate seasons to help keep the firebox warm.

REMOTE CONTROL FEATURE: The Control Module has a built in remote control receiver which allows the user to program the hand held remote transmitter.

1. There is a switch located on the right side of the Control Module that reads REMOTE/OFF.
2. When the remote/off switch is in the OFF position the appliance will operate from an appliance mounted rocker switch (#3) or optional wall switch connected to the two BROWN wires on the Control Module.
3. When the remote/off switch is in the REMOTE position the appliance will operate from the Remote Control transmitter.

The Control Module must be programmed to the Remote Control.

1. To program, located the learn button on the left side of the Control Module Note: Press and release the learn button. There will be a beep sound from the Control Module, then press any key on the remote transmitter. Once the internal receiver accepts the transmitter code there will be a series of confirming beeps.
2. The remote system is ready for use. Please refer to the separate Multifunction Remote Control Instruction manual for programming and detailed operational information.

REMOTE CONTROL OPERATION

1. The MODE button toggles between ON, THERMO and OFF.
2. The FLAME MAIN button will control the level of the torch burners on the DVL or the burner in front of the large rear log on the DVTT with level 7 being the largest flame and level 1 shutting off the flame.
3. The LIGHTS button will control the level of intensity of the media light on the DVL or the overhead light of the DVTT with level 6 being the brightest and level 0 being off.
4. The FLAME REAR and the FAN button are not active functions of this fireplace.

POWER SUPPLY SYSTEM

The Gas Control system is powered by a standard 110 volt AC through a 6.0 volt DC adaptor. The AC adaptor is connected to the Control Module with two 1/4" female terminals.

This control system also includes a Battery Back-up pack that allows the Gas Control system only to operate in the event of a power outage.

Notice: The Accent Light and/or Blower features will not operate during a power outage.

Notice: All Batteries should be replaced at least once each year, preferably at the beginning of the heating season.

CAUTION

Fire or explosion hazard. Can cause property damage, sever injury or death.

Do not attempt to take apart the gas control or to clean it. Improper assembly and cleaning can cause unreliable operation.

MULTIFUNCTION REMOTE MAINTENANCE INSTRUCTIONS

MAINTENANCE

Maintenance frequency must be determined individually for each application. Some considerations are:

- Exposure to water, dirt, chemicals and heat can damage the gas control and shut down the control system.
- Cycling frequency. Appliances that may cycle 20,000 times annually should be checked monthly.
- Intermittent use. Appliances that are used seasonally should be checked before shutdown and again before the next use.
- Dusty, wet or corrosive environment. Because these environments can cause the gas control to deteriorate more rapidly, the system should be checked more often.
- Any control should be replaced if it does not perform properly on checkout or service. In addition, replace any module if it is wet or looks like it has been wet.

SERVICE

Do not disassemble the gas control; it contains non-replaceable components. Attempted disassembly or repair can damage the control.

Exactly follow the warnings and the lighting instructions.

1. Before lighting, smell around the appliance area for gas. If the appliance uses LP (bottled) gas, be sure to smell next to the floor because LP gas is heavier than air. If you smell gas, immediately shut off the manual valve in the gas piping to the appliance or on LP at the tank. Do not try to light any appliance. Do not touch any electrical switch or use the phone. Leave the building and call your gas supplier. If your gas supplier cannot be reached, call the fire department.
2. The gas control must be replaced if it has been flooded with water. Call a qualified service technician.
3. The gas control is a safety device. It must be replaced in case of any physical damage such as bent terminals, missing parts, stripped threads, or evidence of exposure to excessive heat.

Follow the operating instructions provided by the manufacturer of your heating appliance.

TROUBLESHOOTING

IMPORTANT: All service and trouble-shooting procedures should be performed by an experienced qualified service technician.

If the pilot will not stay lit:

1. Confirm that the "S" wire and the "I" wire are properly connected to the Control Module "S" and "I" terminals.
2. Confirm that the Spark to Pilot burner is properly grounded to the Gas Control Valve and the Control Module.
3. Check the power source from the 6-volt power adaptor or the Battery Back-up pack connection and condition of batteries.
4. Check the position of the CONTINUOUS PILOT switch on the Control Module. If main burner does not come ON when the manual switch and remote control is turned ON:
 - a. Confirm that the pilot sparks and lights.
 - b. Check the two pin plastic connectors that plug into the face of the Gas Control valve.
 - c. Confirm that the Gas Control valve is properly grounded to the Control Module.

OPTIONAL GAS CONVERSION KITS

Please contact your dealer or distributor for the proper Conversion kit for these fireplace models.

CAUTION

The gas type has been pre-set at the factory and must not be changed unless a complete conversion is made which includes changing of the gas pilot injector, air shutter settings and main burner orifice.

MULTIFUNCTION REMOTE WIRING DIAGRAM

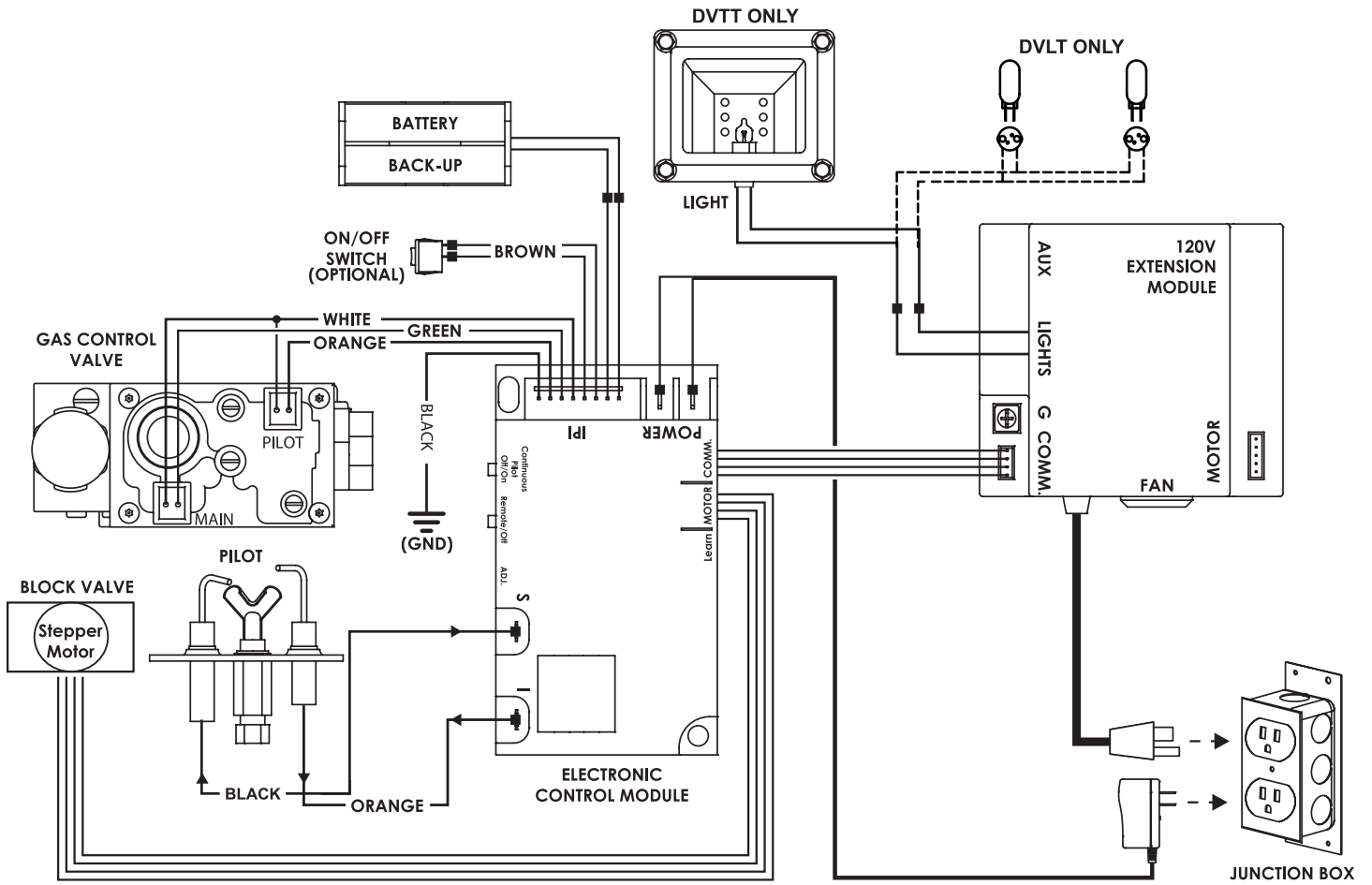

Notice: For Multi-Function Remote Fireplace models with Premium Multi-Function Remote Control, Refer to the separate instructions for operation of the remote control system.

Figure 56

PREMIUM MULTIFUNCTION REMOTE OPERATION INSTRUCTIONS

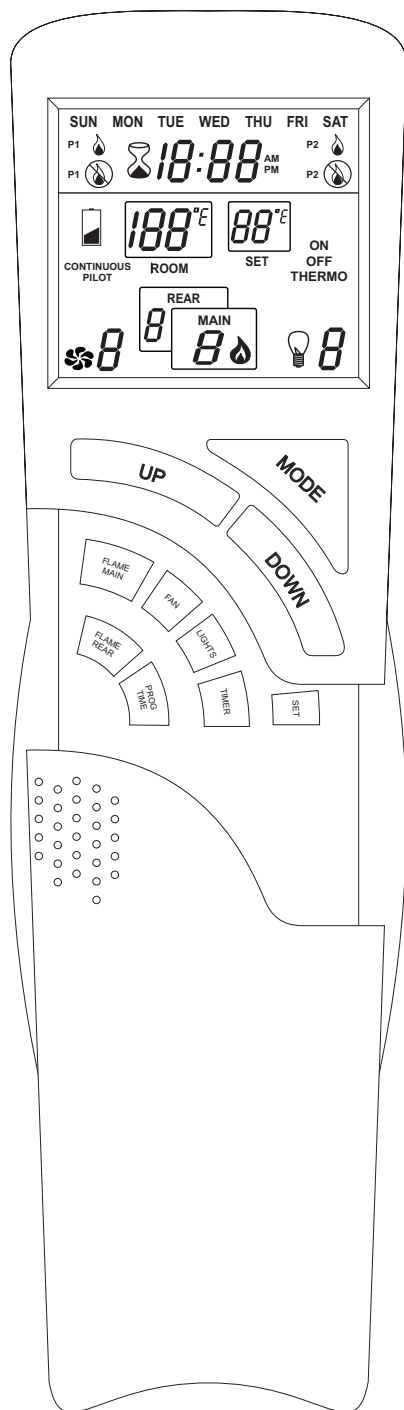

Display	Description
P1	PROGRAM 1 - ON
P1	PROGRAM 1 - OFF
	COUNTDOWN TIMER
P2	PROGRAM 2 - ON
P2	PROGRAM 2 - OFF
	BATTERY LOW
CONTINUOUS PILOT	CONTINUOUS PILOT CHOICE
	ROOM TEMPERATURE
	THERMOSTAT SETTING
ON OFF THERMO	DISPOSITION OF HEATER
	FAN
	REAR AND MAIN FLAME MODULATION
	LIGHTS

Button	Description
	MODE
	UP
	DOWN
	FLAME MAIN
	FAN
	TIMER
	SET
	FLAME REAR
	PROG/TIME

IMPORTANT

Notice: Please retain these instructions for future reference to program and operate this remote control.

Notice: It is recommended that batteries in the hand held remote and the back up batteries (located near the gas control compartment) be replaced on a yearly basis to ensure sufficient power requirements.

PREMIUM MULTIFUNCTION REMOTE OPERATION INSTRUCTIONS

Initial Remote Setup

Installation of two AAA-size batteries will activate the setup mode. Setup mode can also be activated by pressing the FLAME REAR and PROG/TIME buttons simultaneously for 5 seconds. The control will exit setup mode if no button is pressed for 20 seconds. Appropriate icon on LCD will flash when ready for setup.

1. Press the UP or Down button in setup mode to change the temperature scale. Press SET button to skip or advance to Fuel Type setup.
2. To switch between the NG and LP step motor settings, press and hold the learn button for 20 seconds. The module should emit a short beep (less than 1 second) to indicate that the control was switched from NG (default setting) to LP. When switching back from LP to NG, the control should emit a long beep (3 seconds).

Note: When installing or replacing batteries, the Remote Control handset should be reset to the appropriate NG or LP icon depending on the appliance gas type specified on the rating plate.

3. Press the UP or Down Button to set the hour. Press SET to advance to minutes.
4. Press the UP or Down button to set minutes. Press SET to advance to AM or PM.
5. Press the UP or Down button to set AM or PM. Press the SET button to advance to the day of week.
6. Use UP or Down button to select the day of the week.
7. The control will exit setup mode in 20 seconds.

Learn Function

1. To program the system to a transmitter, press the LEARN button on the Main Module. A single audible beep will be heard.
2. Press the MODE button on the transmitter to learn the transmitter to the system. A series of beeps will be heard.
3. Up to two additional (NON-THERMOSTATIC) transmitters can be used simultaneously. To learn additional transmitters, press and release the learn button again, and press the on button on the additional transmitters.
4. To clear all transmitters and start over, press and hold the LEARN button for 10 seconds. A series of three beeps will be heard, and the system is clear.

Child Lock-Out

The Child Lock-out feature can be activated by pressing the PROG/Time and UP buttons simultaneously for five seconds. CP will appear on the LCD in the ROOM box on the screen, and no signals can be sent from the transmitter.

To take the control out of Child Lock-out mode, repeat the above step. CP will disappear from the screen.

Thermal Safety

When the internal components of the Main Module reach 170°F, the unit will automatically shut off, and send a repetitive audible signal. The unit can be turned back on when the module cools below 160°

Communication Safety

When in the Thermostat or Program Mode, the transmitter will send a silent signal to the module every 15 minutes. If a signal is not received within 2 hours due to dead batteries, lost transmitter, or transmitter out of range, the unit will automatically shut down, and the module will send a repetitive audible signal.

Low Battery Indicator

A low battery icon will appear on LCD screen when transmitter batteries reach low voltage level. When the batteries are replaced, Initial Remote Setup, Learn Function and any programming will need to be redone.

MODE Button

The MODE button cycles the unit through the basic operational modes.

1. When off, press and release the MODE button to turn the unit on in Manual mode.
2. Press and release the MODE button again, and the unit will operate in the Thermostat mode.
3. Press and release the MODE button again, and the unit will turn off.

Program Mode

The Program function is controlled by the PROG/TIME button. The control may be programmed for up to two settings for weekdays and two settings for weekends. The control is preset to factory settings.

When the Program Mode is activated, the unit will automatically be operating in the Thermostat Mode. The unit will turn on or off based upon room and set temperature.

To activate the Program mode, press and release the PROG/TIME button.

1. To change the settings for the Program mode, press and hold the PROG/TIME button for 5 seconds. The program feature will flash at the top of the screen.

For Weekday Settings

2. Press the UP or DOWN button to change the setting of the weekday (Mon,Tues,Wed,Thurs,Fri) P1 ON. Press and release the SET button.
3. Press the UP or DOWN button to change the setting of P1 OFF. Press and release the SET button.
4. Press the UP or DOWN button to change the setting of P2 ON. Press and release the SET button.
5. Press the UP or DOWN button to change the setting of P2 OFF. Press and release the SET button.

For Weekend Settings

6. Press the UP or DOWN button to change the setting of the weekend (Sat, Sun) P1 ON. Press and release the SET button.
7. Press the UP or DOWN button to change the setting of P1 OFF. Press and release the SET button.
8. Press the UP or DOWN button to change the setting of P2 ON. Press and release the SET button.
9. Press the UP or DOWN button to change the setting of P2 OFF. Press and release the SET button.
10. The Program Mode has been re-programmed.

PREMIUM MULTIFUNCTION REMOTE OPERATION INSTRUCTIONS

Countdown Timer

The Countdown Timer Mode allows the control to operate the unit for up to 3 hours, in 10-minute increments. It can be operated in either the Manual or Thermostat Modes.

1. To enter Timer Mode, press and release the TIMER button. The Timer icon will flash.
2. Press the UP or DOWN button to set the running time, in 10-minute increments. Press and release the SET button. The timer will run for the set time duration.
3. Pressing the TIMER button while in Timer Mode will terminate the Timer operation. The Timer operation will also terminate if the MODE button is cycled to off.

Thermostat Mode

The unit is placed in Thermostat Mode using the MODE button. Placing the unit in Thermostat Mode will activate the numbers in the smaller window on the LCD screen.

1. Press the UP or DOWN button to change the thermostat set temperature. When the desired set temperature appears, press and release the SET button to set.
2. If the SET button is not pressed, the set temperature will automatically be set after 5 seconds.
3. The Thermostat Mode can be de-activated by pressing the MODE button.

Thermostatic Flame Modulation

This control can perform Main Flame Modulation using the Thermostat. The control will shut the unit off when the room temperature reaches 2° above set temperature. The Thermostat will automatically modulate the main flame as follows:

2° above set temperature	OFF
1° above set temperature	Flame Level 1
at set temperature	Flame Level 2
1° below set temperature	Flame Level 3
2° below set temperature	Flame Level 4
3° below set temperature	Flame Level 5
4° below set temperature	Flame Level 6
5° below set temperature	Flame Level 7

Manual Flame Modulation – Main Flame

To change the Flame Level manually, press the FLAME MAIN button. The current level will show in the MAIN box on the LCD screen.

1. Press the UP or DOWN button to change the Flame Level.
2. When the unit is turned on, whether in Manual, Thermostatic, or Program Mode, the Main Flame will automatically ignite at the High (7) setting. After 5 seconds, the flame will default to the previous setting.

Manual Flame Modulation - Rear Flame

Feature not available.

Fan Control

The unit must be ON to operate the Fan.

The Fan will turn on after 5 minutes of operation. Once the Fan comes on, it can be controlled using the FAN button.

1. Press the FAN button, and the fan icon and speed will appear on the LCD screen.
2. Press the UP or DOWN button to control the fan speed (0-6). Press the DOWN button until 0 Level is reached to turn the Fan off.
3. The fan will run for 12 minutes after the unit is shut off in any mode. The fan may not be controlled during this period.

Accent Light

Not available on all models

The unit does NOT have to be on to operate the lights.

Lights are controlled by the LIGHTS button on the transmitter.

1. Press the LIGHTS button and the light icon and intensity level will appear on the LCD screen.
2. Press the UP or DOWN button to set the light intensity level. Press SET, or wait 7 seconds, and the light intensity setting will be established.

Continuous Pilot

The unit can be changed from Intermittent Pilot Ignition (IPI), to Continuous, or standing, pilot.

1. To place the unit in continuous pilot mode, press and release the PROG/TIME and the FLAME MAIN buttons simultaneously. Continuous Pilot will appear on the LCD screen.
2. Repeat the simultaneous PROG/TIME and FLAME MAIN push to place the unit back in IPI mode.
3. This feature can also be activated by the Continuous Pilot (On/Off) switch on the Main Module.

MAINTENANCE AND SERVICE

Please Note

It is normal for appliances fabricated of steel to give off some expansion and/or contraction noise during the start up or cool down cycle. Similar noises are found with your furnace heat exchanger or car engine.

It is not unusual for your gas fireplace to give off some odor the first time it is burned. This is due to the curing of the paint and any undetected oil from the manufacturing process.

Please ensure that your room is well ventilated - open all windows.

It is recommended that you burn your fireplace for at least six hours the first time you use it.

IMPORTANT: Turn off gas before servicing appliance. It is recommended that a qualified service person perform these check-ups at the beginning of each heating season.

• Clean Burner and Control Compartment

Keep the control compartment, logs, and burner areas surrounding the logs clean by vacuuming or brushing at least twice a year.

Cleaning Procedure

1. Turn off pilot light at control module.
2. Remove 3 piece surround.
3. Remove glass front. (See Glass Removal)
4. Vacuum burner compartment.
5. Reinstall glass front.
6. Replace 3 piece surround.
7. Ignite pilot. (See Lighting Instructions)
8. Operate the pilot burner. If it appears abnormal call a service person.

• Check Vent System

The appliance and venting system should be inspected before initial use and at least annually by a qualified service person. Inspect the external vent cap on a regular basis to make sure that no debris is interfering with the air flow.

Glass Cleaning

It will be necessary to clean the glass periodically. During start-up condensation, which is normal, forms on the inside of the glass and causes lint, dust and other airborne particles to cling to the glass surface. Also initial paint curing may deposit a slight film on the glass. It is therefore recommended that the glass be cleaned two or three times with a non-abrasive household cleaner and warm water (we recommend gas fireplace glass cleaner). After that the glass should be cleaned two or three times during each heating season depending on the circumstances present.

WARNING

Do not operate appliance with the glass front removed, cracked or broken. Replacement of the glass should be done by a licensed or qualified service person.

Only glass approved for use by the manufacturer in fireplace may be used for replacement. The glass replacement should be done by a licensed or qualified service person.

WARNING

1. The use of substitute glass will void all product warranties.
2. Care must be taken to avoid breakage of the glass.
3. Under no circumstances should this appliance be operated without the glass front or with a broken glass front. Replacement of the glass (with gasket) as supplied by the manufacturer should be done by a qualified service person.
4. Do not abuse the glass by striking or hitting the glass.

WARNING

Do not use abrasive cleaners on glass. Do not attempt to clean glass when glass is hot.

MAINTENANCE AND SERVICE

Barrier Screen Removal and Replacement

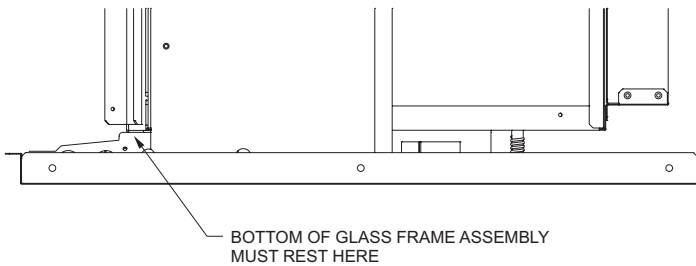

Figure 57

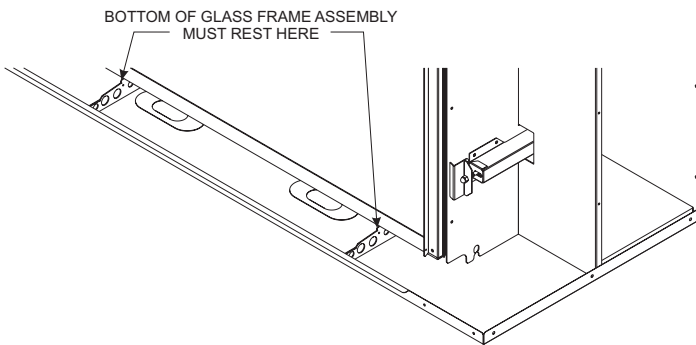

Figure 58

4. Grasp the glass frame on the top and the bottom. Pull the glass straight out to disengage the glass from the fireplace. Pull the bottom out of the opening first and then guide the top out of the fireplace opening.

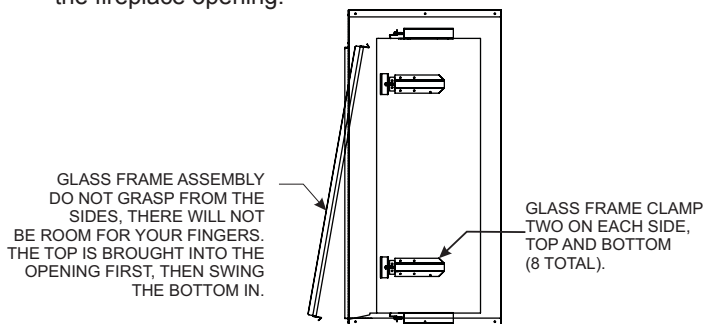

Figure 59

5. To replace, reverse the above steps. The glass sits on a "two step ledge" and the glass must be placed on the top level to properly engage the firebox face. The glass cannot sit on the angled part of the ledge or you will not be able to latch the bottom latches.

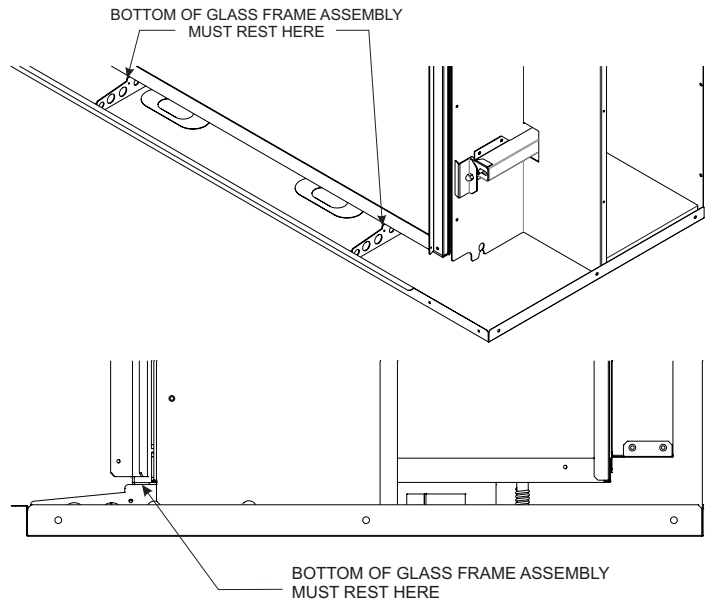

Figure 60

ACCESSORIES

The following accessory parts can be obtained from your Empire Comfort Systems dealer. If you need additional information beyond what your dealer can furnish, contact Empire Comfort Systems Inc., Nine Eighteen Freeburg Ave., Belleville, Illinois 62220-2623.

DECORATIVE ACCESSORIES

Part Number	Description	Fits Models
DG7AB	Decorative Glass - Aqua Blue	DVLT
DG7GC	Decorative Glass - Glacier Ice	DVLT
DG7SL	Decorative Glass - Sangria Luster	DVLT

DVLT(36,42)FP92 REPLACEMENT PARTS LIST

Index No.	Part Number		Description
	DVLT36FP92(N,P)	DVLT42FP92(N,P)	
1	28235	28235	Top Standoff (Qty. 2)
2	28250	28250	Standoff Support
3	28251	28251	Standoff Support
4	R10916	R10916	Light Socket
5	R10928	R10928	Light Bulb, 35 W
6	28962	28962	High Wind Baffle
7	28275	28275	Valve Mount Plate
8	28267	28267	Burner Support (2 Required for DVLT42 models)
9	R3490	R3490	Junction Box
10	R3492	R3492	3-Prong Receptacle
11	28963	28963	Pilot Shield
12	R10896	R10897	Burner Tube
13	28961	28961	Air Chute
14	R11167	R11167	Flex, 90 Degree
15	R10914	R10914	Pilot Assembly (NAT)
15	R10918	R10918	Pilot Assembly (LP)
16	R10898	R10899	Back Burner
17	28304	28303	Mesh
18	R10915	R10915	Flex, Straight
19	28269	28269	Media Basket Leg
20	28256	28257	Media Basket
21	28319	28312	Modern Grate Assembly
22	34856	34857	Glass Frame Assembly
23	34380	34381	Screen Frame Assembly
24	Q0002	Q0003	Replacement Screen
25	R10920	R10920	Valve, American Flame
26	R10919	R10919	Valve, Step Down
27	R11044	R11044	Regulator (Nat)
27	R11045	R11045	Regulator (LP)
28	R11007	R11007	Control Module
29	R10416	R10416	120V Extension Module
N/S	R10419	R10419	7.5 V AC Adapter
N/S	31094	31094	Air Duct Extension
N/S	31254	31095	Air Baffle
N/S	31234	31234	Venturi Target
N/S	R10418	R10418	Battery Back-up
N/S	R10911	R11166	Non-Combustible Board
N/S	28236	28236	Intake Collar
N/S	R1569	R1569	Tinnerman Clip (Qty 2)
N/S	R11006	R11006	Remote Control
N/S	DVFQ36TWBL	DVFQ42TWBL	Fireplace Barrier

N/S - Not Shown

Use Only Manufacturer's Replacement Parts. Use of Any Other Parts Could Cause Injury Or Death.

DVLT(36,42)FP92 EXPLODED VIEW

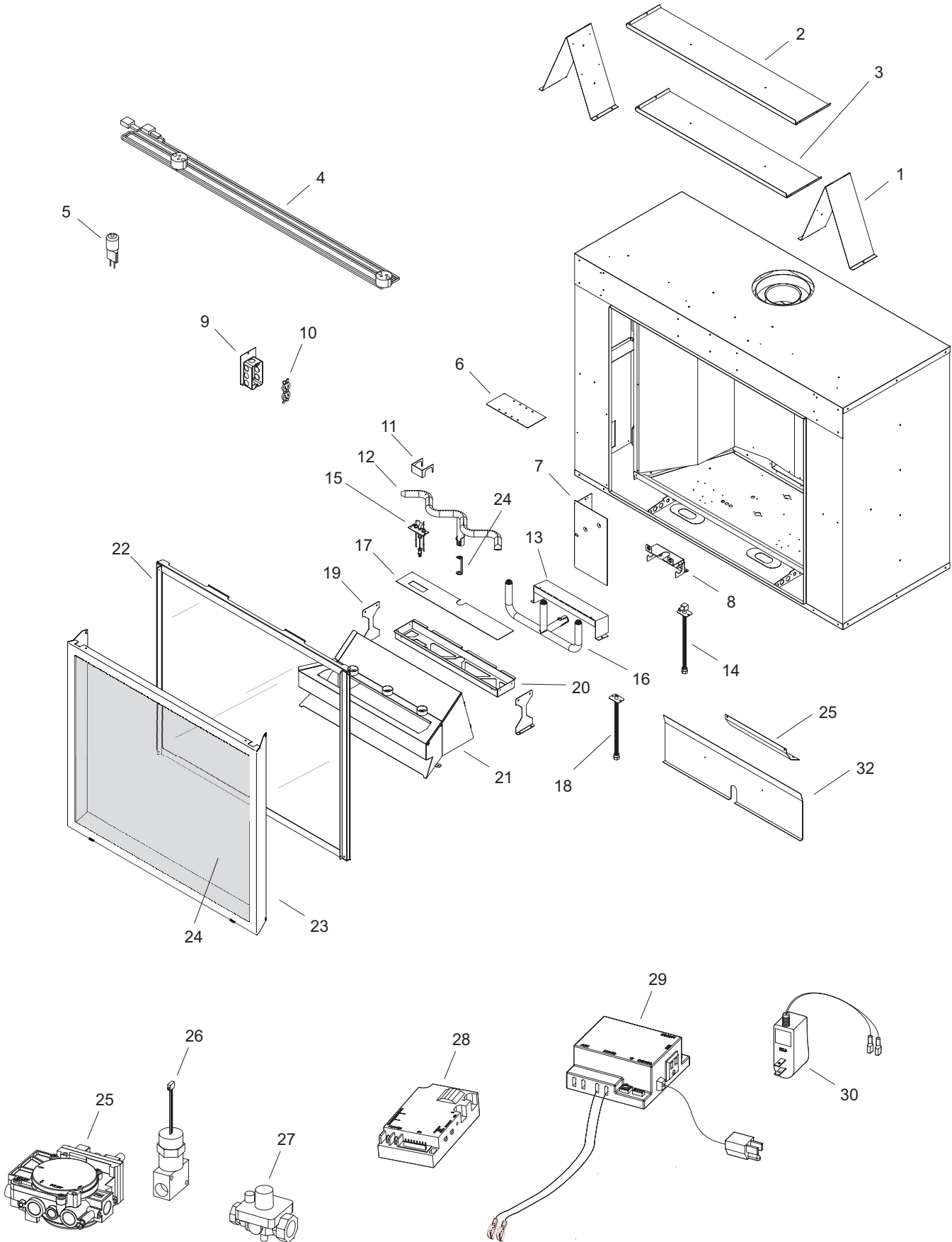

Use Only Manufacturer's Replacement Parts. Use of Any Other Parts Could Cause Injury Or Death.

DVTT(36,42)FP92 REPLACEMENT PARTS LIST

Index No.	Part Number		Description
	DVTT36FP92(N,P)	DVTT42FP92(N,P)	
1	28235	28235	Top Standoff (Qty. 2)
2	28250	28250	Standoff Support
3	28251	28251	Standoff Support
4	R11117	R11117	Accent Lamp
5	R9343	R9343	Accent Lamp Gasket
6	R9341	R9341	Accent Lamp Glass
7	R9342	R9342	Accent Lamp Bezel
8	28962	28962	High Wind Baffle
9	28254	28295	Firebox Liner, Left Side
10	28253	28294	Firebox Liner, Back
11	28255	28296	Firebox Liner, Right Side
12	R3490	R3490	Junction Box
13	R3492	R3492	3-Prong Receptacle
14	28307	28307	Burner Tube Air Deflector
15	R10900	R10901	Burner Tube
16	R10914	R10914	Pilot Assembly (Nat)
16	R10918	R10918	Pilot Assembly (LP)
17	28300	31148	Burner Assembly
18	R11167	R11167	Flex, 90 Degree
19	28275	28275	Valve Mount Plate
20	R10891	R10895	Grate Assembly
21	28969	28966	Refractory Support Bracket
22	34856	34857	Glass Frame Assembly
23	34830	34831	Screen Frame Assembly
24	Q0002	Q0003	Replacement Screen
25	R10920	R10920	Valve, American Flame
26	R10919	R10919	Valve, Step Down
27	R11044	R11044	Regulator (Nat)
27	R11045	R11045	Regulator (LP)
28	R11007	R11007	Control Module
29	R10416	R10416	120V Extension Module
30	R10419	R10419	7.5 V AC Adapter
N/S	R10418	R10418	Battery Back-up
N/S	R10922	R11166	Non-Combustible Board
N/S	28236	28236	Intake Collar
N/S	29136	29137	Liner, Hearth Floor
N/S	R11006	R11006	Remote Control
N/S	DVFQ36TWBL	DVFQ42TWBL	Fireplace Barrier

N/S - Not Shown

See Pages 29 to 37 for ordering correct logs.

Use Only Manufacturer's Replacement Parts. Use of Any Other Parts Could Cause Injury Or Death.

DVTT(36,42)FP92 EXPLODED VIEW

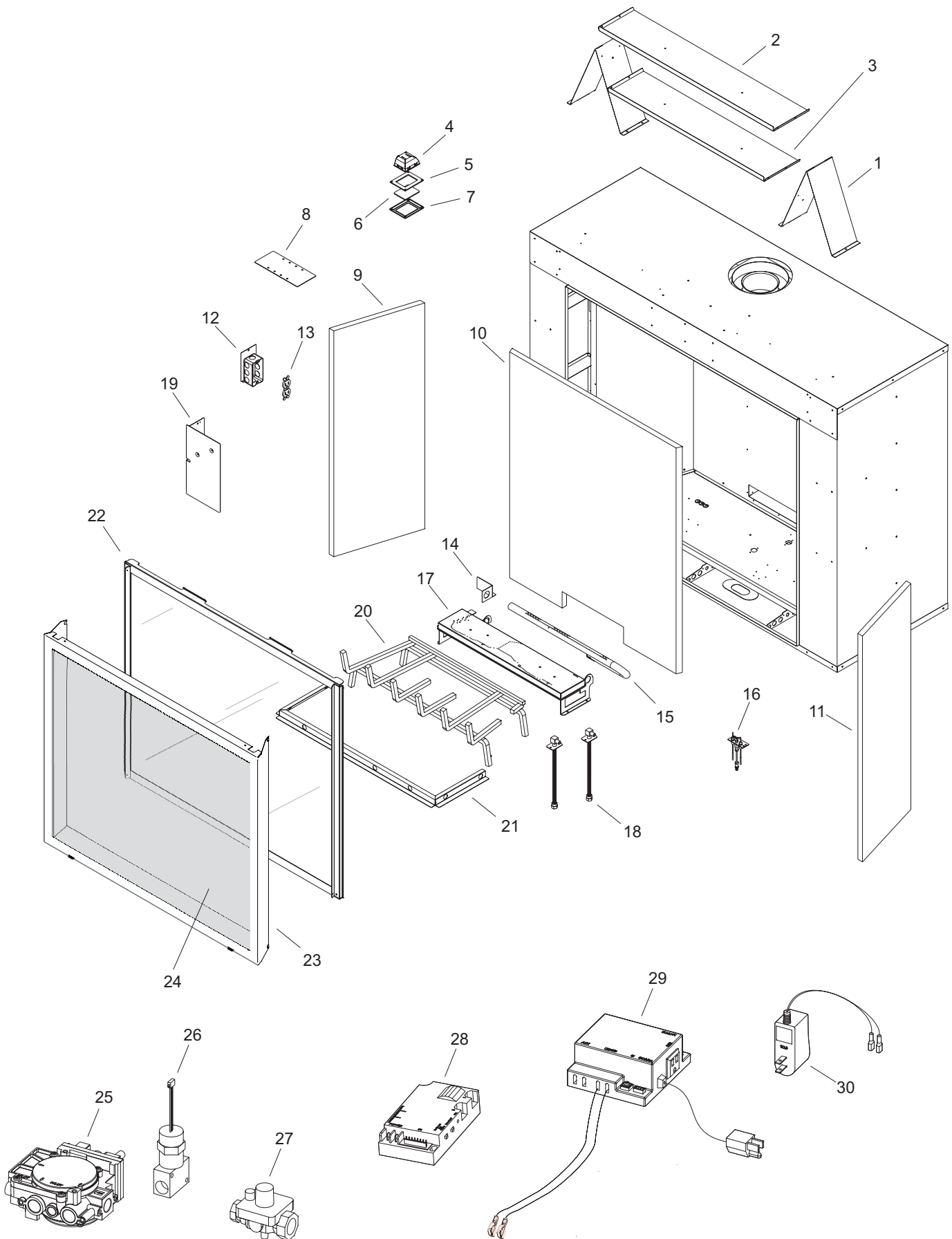

MASTER PARTS DISTRIBUTOR LIST

To Order Parts Under Warranty, please contact your local Empire dealer. See the dealer locator at www.empirecomfort.com. To provide warranty service, your dealer will need your name and address, purchase date and serial number, and the nature of the problem with the unit.

To Order Parts After the Warranty Period, please contact your dealer or one of the Master Parts Distributors listed below. This list changes from time to time. For the current list, please click on the Master Parts button at www.empirecomfort.com. Please note: Master Parts Distributors are independent businesses that stock the most commonly ordered Original Equipment repair parts for Heaters, Grills, and Fireplaces manufactured by Empire Comfort Systems Inc.

Dey Distributing

1401 Willow Lake Boulevard
Vadnais Heights, MN 55101

Phone: 651-490-9191

Toll Free: 800-397-1339

Website: www.deydistributing.com

Parts: Heater, Hearth and Grills

Victor Division of F. W. Webb Company

200 Locust Street
Hartford, CT 06114

Phone: 860-722-2433

Toll Free: 800-243-9360

Fax: 860-293-0479

Toll Free Fax: 800-274-2004

Websites: www.fwebb.com & www.victormfg.com

Parts: Heater, Hearth and Grills

East Coast Energy Products

10 East Route 36
West Long Branch, NJ 07764

Phone: 732-870-8809

Toll Free: 800-755-8809

Fax: 732-870-8811

Website: www.eastcoastenergy.com

Parts: Heater, Hearth and Grills

HOW TO ORDER REPAIR PARTS

Parts Not Under Warranty

Parts can be ordered through your Service Person, Dealer, or a Master Parts Distributor. See this page for the Master Parts Distributors list. For best results, the **service person or dealer** should order parts through the distributor. Parts can be shipped directly to the **service person/dealer**.

Warranty Parts

Warranty parts will need a proof of purchase and can be ordered by your Service Person or Dealer. Proof of purchase is **required** for warranty parts.

All parts listed in the Parts List have a Part Number. When ordering parts, first obtain the Model Number and Serial Number from the name plate on your equipment. Then determine the Part Number (**not** the Index Number) and the Description of each part from the following illustration and part list. Be sure to give all this information . . .

Appliance Model Number _____ Part Description _____

Appliance Serial Number _____ Part Number _____

Type of Gas (Propane or Natural) _____

Do not order bolts, screws, washers or nuts. They are standard hardware items and can be purchased at any local hardware store.

Shipments contingent upon strikes, fires and all causes beyond our control.

JUNCTION BOX WIRING INSTALLATION INSTRUCTIONS

⚠ CAUTION

ALL WIRING SHOULD BE DONE BY A QUALIFIED ELECTRICIAN AND SHALL BE IN COMPLIANCE WITH ALL LOCAL, CITY AND STATE BUILDING CODES. BEFORE MAKING THE ELECTRICAL CONNECTION, MAKE SURE THAT MAIN POWER SUPPLY IS DISCONNECTED. THE APPLIANCE, WHEN INSTALLED, MUST BE ELECTRICALLY GROUNDED IN ACCORDANCE WITH LOCAL CODES OR, IN THE ABSENCE OF LOCAL CODES, WITH THE NATIONAL ELECTRICAL CODE ANSI/NFPA 70 (LATEST EDITION).

A factory installed junction box is located on the lower right side of the fireplace. Wiring must be fed to the junction box and attached to the receptacle that is provided. Leave approximately 6" of wire in the junction box for connection.

Attach black wire to one side of the receptacle and white wire to opposite side of receptacle. The ground wire should be attached to the green (ground) screw.

Install the receptacle into the junction box. Attach cover plate.

JUNCTION BOX CONNECTIONS

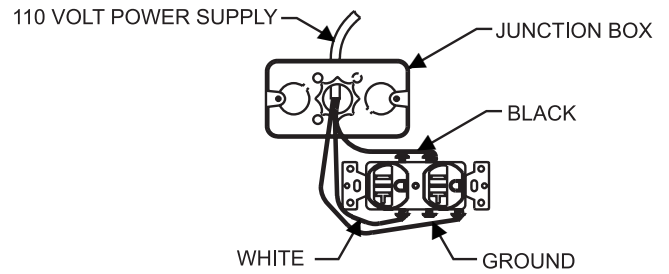

Figure 61

ACCENT LAMP LIGHT REPLACEMENT

Your Luxury Direct Vent Gas Fireplace comes equipped with our "Accent Lamp." The light has been pre-wired and is controlled from the remote.

DVLT ACCENT LAMP LIGHT REPLACEMENT

If in the event the lamp or lens needs to be replaced, follow the instructions below:

1. Unplug the remote from the junction box or disconnect all power to the fireplace.
2. Remove the screen (if equipped) and remove the front panels.
3. Remove the glass frame assembly by unhooking the 8 spring clips around the glass.
4. Remove about 1/4" of the media (beads) across the top of the burner.
5. Remove the two screws on the sides of the burner cover.
6. Grasp the burner cover and lift up while slightly tipping the grate forward. **See Figure 62.**
7. The light bulbs are located underneath the media basket.
8. Pull the old bulb out and push the new bulb in.
IMPORTANT: Do not handle the lamp (bulb) with bare fingers, protect with clean dry cloth.
9. Place the burner cover back in place by tipping it back into place while lowering it down.
10. Make sure the glass media doesn't hold the burner cover up. Move any beads out of the way if it does.
11. Re-attach the grate down with the two screws. Replace the glass media over the burner.

NOTE: The lamp will pull straight out of the socket. Replace with 35 Watt/120 Volt Halogen bulb. When re-installing, ensure integrity of gasket seal.

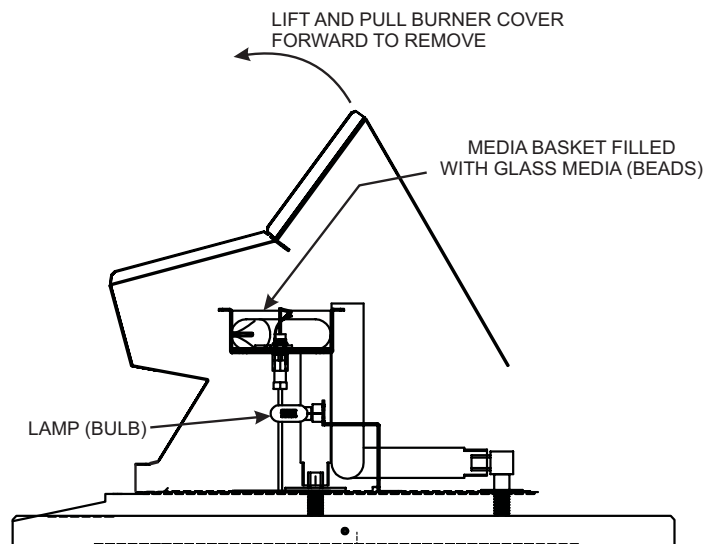

Figure 62 - Side view of burner

ACCENT LAMP LIGHT REPLACEMENT

DVTT ACCENT LAMP LIGHT REPLACEMENT

If in the event the lamp or lens needs to be replaced, follow the instructions below:

1. Unplug the remote from the junction box or disconnect all power to the fireplace.
2. Remove the 4 screws that secure the lens frame. This frame retains the glass lens. The bulb can now be accessed.
IMPORTANT: Do not handle the lamp (bulb) with bare fingers, protect with clean dry cloth.

NOTE: The lamp will pull straight out of the socket. When re-installing, ensure integrity of gasket seal.

Replacement Bulbs

Replacement bulbs are available locally at most hardware, appliance or building supply stores. Replace with a G9 (120V/25W) series halogen bulb.

THE FIREBOX MUST BE SEALED.

Over-tightening the screws could break the lens. "Light Leakage" from the upper area may be observed. The holes in the lamp housing are necessary for ventilation and must not be covered.

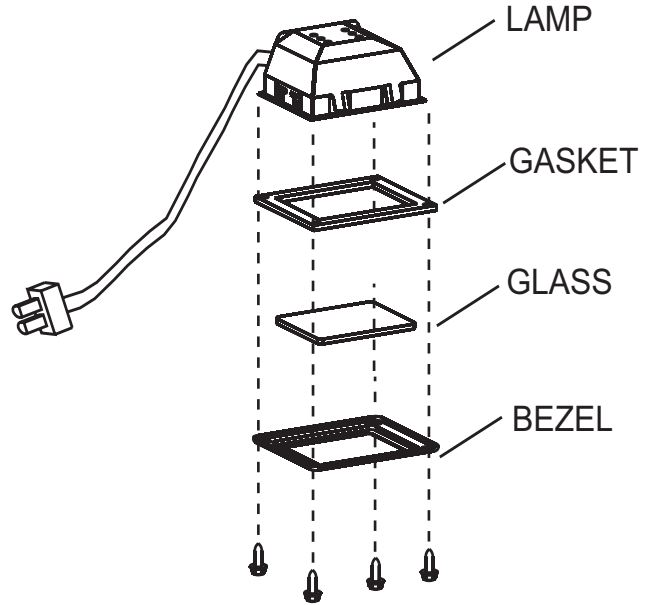

Figure 64 - Accent Lamp Parts

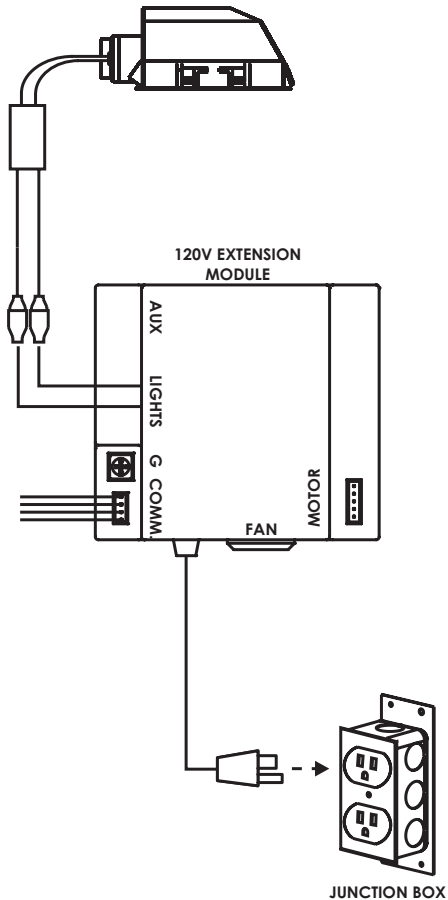

Figure 63 - Accent Lamp Wiring

WARRANTY TERMS

Empire Comfort Systems Inc. warrants this hearth product to be free from defects at the time of purchase and for the periods specified below. Hearth products must be installed by a qualified technician and must be maintained and operated safely, in accordance with the instructions in the owner's manual. This warranty applies to the original purchaser only and is not transferable. All warranty repairs must be accomplished by a qualified gas appliance technician.

Limited Lifetime Parts Warranty – Combustion Chamber, Heat Exchanger, and Factory-Installed Glass

If the combustion chamber, heat exchanger (see parts list) or factory-installed glass fails because of defective workmanship or material, Empire will repair or replace at Empire's option.

Limited Three-Year Parts Warranty – All Other Components

(Except Remote Controls, Thermostats, Accessories and Replacement Parts)

Should any part fail because of defective workmanship or material within three years from the date of purchase, Empire will repair or replace at Empire's option.

Limited One-Year Parts Warranty – Remote Controls, Thermostats, Accessories, and Parts

Should any remote control, thermostat, accessory, or other part fail because of defective workmanship within one year from the date of purchase, Empire will repair or replace at Empire's option.

Duties Of The Owner

The appliance must be installed by a qualified installer and operated in accordance with the instructions furnished with the appliance.

A bill of sale, cancelled check, or payment record should be kept to verify purchase date and establish warranty period. Ready access to the appliance for service.

What Is Not Covered

Damages that might result from the use, misuse, or improper installation of this appliance.

Travel, diagnostic costs and freight charges on warranted parts to and from the factory.

Claims that do not involve defective workmanship or materials.

Unauthorized service or parts replacements.

Removal and reinstallation cost.

Inoperable due to improper or lack of maintenance.

How To Get Service

To make a claim under this warranty, please have your receipt available and contact your installing dealer. Provide the dealer with the model number, serial number, type of gas, and purchase verification. The installing dealer is responsible for providing service and will contact the factory to initiate any warranted parts replacements. Empire will make replacement parts available at the factory. Shipping expenses are not covered.

If, after contacting your Empire dealer, service received has not been satisfactory, contact: Consumer Relations Department, Empire Comfort Systems Inc., PO Box 529, Belleville, Illinois 62222, or send an e-mail to info@empirecomfort.com with "Consumer Relations" in the subject line.

Your Rights Under State Law

This warranty gives your specific legal rights, and you may also have other rights, which vary from state to state.

IMPORTANT SAFETY INFORMATION

Before enclosing the vent pipe assembly, operate the appliance to ensure it is venting properly.

- ⚠ DANGER:** Indicates a hazardous situation which, if not avoided, will result in death or serious injury.
- ⚠ WARNING:** Indicates a hazardous situation which, if not avoided, could result in death or serious injury.
- ⚠ CAUTION:** Indicates a hazardous situation which, if not avoided, could result in minor or moderate injury.
- NOTICE:** Addresses practices not related to personal injury.

DO NOT OPERATE THIS APPLIANCE WITHOUT GLASS FRONT PANEL INSTALLED

- If this appliance is installed directly on carpeting, tile or other combustible material other than wood flooring the appliance shall be installed on a metal or wood panel extending the full width and depth of the appliance.
The base referred to above does not mean the fireproof base as used on wood stoves. The protection is for rugs that are extremely thick and light colored tile.
- Children and adults should be alerted to the hazards of high surface temperatures and should stay away to avoid burns or clothing ignition.
- Young children should be carefully supervised when they are in the same room as the appliance.
- Clothing or other flammable material should not be placed on or near the appliance.
- Adequate accessibility clearances for servicing and proper operation.
- This appliance must not share or be connected to a flue serving a separate solid-fuel burning appliance.
- Keep the area around your appliance clear of combustible materials, gasoline and other flammable vapor and liquids.
- Under no circumstances should any solid fuels (wood, coal, paper or cardboard etc.) be used in this appliance.
- The flow of combustion and ventilation air must not be obstructed in any way.
- Young children should be carefully supervised when they are in the same room as the appliance. Toddlers, young children, and others may be susceptible to accidental contact burns. A physical barrier is recommended if there are at-risk individuals in the house. To restrict access to a fireplace or stove, install an adjustable safety gate to keep toddlers young children, and other at-risk individuals out of the room and away from hot surfaces.
- A barrier designed to reduce the risk of burns from the hot viewing glass is provided with this appliance and shall be installed for the protection of children and other at-risk individuals.
- If the barrier becomes damaged, the barrier shall be replaced with the manufacturer's barrier for this appliance.
- Any safety screen, guard, or barrier removed for servicing an appliance must be replaced prior to operating the appliance.

- Due to high temperatures the appliance should be located out of traffic and away from furniture and draperies.
- The glass front or any part removed for servicing the appliance must be replaced prior to operating the appliance. Work should be done by a qualified service person.
- Keep burner and control compartment clean.
- Vent cap is hot while fireplace is in operation.
- Installation and repair should be done by a qualified service person. The appliance should be inspected before use and at least annually by a qualified service person. More frequent cleaning may be required due to excessive lint from carpeting, bedding materials, etc. It is imperative that control compartments, burners and circulating air passageways of the appliance be kept clean.
- Do not put anything around the fireplace that will obstruct the flow of ventilation air.
- Clearance in accordance with local installation codes and the requirements of the gas supplier.
- Do keep the appliance area clear and free from combustible material, gasoline and other flammable vapors and liquids.
- Do examine venting system periodically and replace damaged parts.
- Do make a periodic visual check of pilot and burners. Clean and replace damaged parts.

⚠ CAUTION

The glass used in your fireplace is ceramic glass. If the glass is cracked or damaged in any way, it should be replaced only with a complete glass frame assembly from Empire. See parts list on Pages 48 to 51 for ordering.

- Do not use this fireplace if any part has been under water. Immediately call a qualified service technician to inspect the heater and to replace any part of the control system and any gas control which has been under water.
- Any safety screen or guard removed for servicing an appliance must be replaced prior to operating the appliance.

SAFETY INFORMATION FOR USERS OF LP-GAS

Propane (LP-Gas) is a flammable gas which can cause fires and explosions. In its natural state, propane is odorless and colorless. You may not know all the following safety precautions which can protect both you and your family from an accident. Read them carefully now, then review them point by point with the members of your household. Someday when there may not be a minute to lose, everyone's safety will depend on knowing exactly what to do. If, after reading the following information, you feel you still need more information, please contact your gas supplier.

LP-GAS WARNING ODOR

If a gas leak happens, you should be able to smell the gas because of the odorant put in the LP-Gas. That's your signal to go into immediate action!

- Do not operate electric switches, light matches, use your phone. Do not do anything that could ignite the gas.
- Get everyone out of the building, vehicle, trailer, or area. Do that IMMEDIATELY.
- Close all gas tank or cylinder supply valves.
- LP-Gas is heavier than air and may settle in low areas such as basements. When you have reason to suspect a gas leak, keep out of basements and other low areas. Stay out until firefighters declare them to be safe.
- Use your neighbor's phone and call a trained LP-Gas service person and the fire department. Even though you may not continue to smell gas, do not turn on the gas again. Do not re-enter the building, vehicle, trailer, or area.
- **Finally**, let the service man and firefighters check for escaped gas. Have them air out the area before you return. Properly trained LP-Gas service people should repair the leak, then check and relight the gas appliance for you.

NO ODOR DETECTED - ODOR FADE

Some people cannot smell well. Some people cannot smell the odor of the chemical put into the gas. You must find out if you can smell the odorant in propane. Smoking can decrease your ability to smell. Being around an odor for a time can affect your sensitivity or ability to detect that odor. Sometimes other odors in the area mask the gas odor. People may not smell the gas odor or their minds are on something else. Thinking about smelling a gas odor can make it easier to smell.

The odorant in LP-gas is colorless, and it can fade under some circumstances. For example, if there is an underground leak, the movement of the gas through soil can filter the odorant. Odorants in LP-Gas also are subject to oxidation. This fading can occur if there is rust inside the storage tank or in iron gas pipes.

The odorant in escaped gas can adsorb or absorb onto or into walls, masonry and other materials and fabrics in a room. That will take some of the odorant out of the gas, reducing its odor intensity.

LP-Gas may stratify in a closed area, and the odor intensity could vary at different levels. Since it is heavier than air, there may be more odor at lower levels. Always be sensitive to the slightest gas odor. If you detect any odor, treat it as a serious leak. Immediately go into action as instructed earlier.

SOME POINTS TO REMEMBER

- Learn to recognize the odor of LP-gas. Your local LP-Gas Dealer can give you a "Scratch and Sniff" pamphlet. Use it to find out what the propane odor smells like. If you suspect that your LP-Gas has a weak or abnormal odor, call your LP-Gas Dealer.
- If you are not qualified, do not light pilot lights, perform service, or make adjustments to appliances on the LP-Gas system. If you are qualified, consciously think about the odor of LP-Gas prior to and while lighting pilot lights or performing service or making adjustments.
- Sometimes a basement or a closed-up house has a musty smell that can cover up the LP-Gas odor. Do not try to light pilot lights, perform service, or make adjustments in an area where the conditions are such that you may not detect the odor if there has been a leak of LP-Gas.
- Odor fade, due to oxidation by rust or adsorption on walls of new cylinders and tanks, is possible. Therefore, people should be particularly alert and careful when new tanks or cylinders are placed in service. Odor fade can occur in new tanks, or reinstalled old tanks, if they are filled and allowed to set too long before refilling. Cylinders and tanks which have been out of service for a time may develop internal rust which will cause odor fade. If such conditions are suspected to exist, a periodic sniff test of the gas is advisable. **If you have any question about the gas odor, call your LP-gas dealer. A periodic sniff test of the LP-gas is a good safety measure under any condition.**
- If, at any time, you do not smell the LP-Gas odorant and you think you should, assume you have a leak. Then take the same immediate action recommended above for the occasion when you do detect the odorized LP-Gas.
- If you experience a complete "gas out," (the container is under no vapor pressure), turn the tank valve off immediately. If the container valve is left on, the container may draw in some air through openings such as pilot light orifices. If this occurs, some new internal rusting could occur. If the valve is left open, then treat the container as a new tank. Always be sure your container is under vapor pressure by turning it off at the container before it goes completely empty or having it refilled before it is completely empty.

REQUIREMENTS FOR MASSACHUSETTS

For all side wall horizontally vented gas fueled equipment installed in every dwelling, building or structure used in whole or in part for residential purposes, including those owned or operated by the Commonwealth and where the side wall exhaust vent termination is less than seven feet above finished grade in the area of the venting, including but not limited to decks and porches, the following requirements shall be satisfied:

1. **INSTALLATION OF CARBON MONOXIDE DETECTORS.**

At the time of installation of the side wall horizontal vented gas fueled equipment, the installing plumber or gas fitter shall observe that a hard wired carbon monoxide detector with an alarm and battery back-up is installed on the floor level where the gas equipment is to be installed. In addition, the installing plumber or gas fitter shall observe that a battery operated or hard wired carbon monoxide detector with an alarm is installed on each additional level of the dwelling, building or structure served by the side wall horizontal vented gas fueled equipment. It shall be the responsibility of the property owner to secure the services of qualified licensed professionals for the installation of hard wired carbon monoxide detectors

 - a. In the event that the side wall horizontally vented gas fueled equipment is installed in a crawl space or an attic, the hard wired carbon monoxide detector with alarm and battery back-up may be installed on the next adjacent floor level.
 - b. In the event that the requirements of this subdivision can not be met at the time of completion of installation, the owner shall have a period of thirty days to comply with the above requirements; provided, however, that during said thirty day period, a battery operated carbon monoxide detector with an alarm shall be installed.
2. **APPROVED CARBON MONOXIDE DETECTORS.** Each carbon monoxide detector as required in accordance with the above provisions shall comply with NFPA 720 and be ANSI/UL 2034 listed and IAS certified.
3. **SIGNAGE.** A metal or plastic identification plate shall be permanently mounted to the exterior of the building at a minimum height of eight feet above grade directly in line with the exhaust vent terminal for the horizontally vented gas fueled heating appliance or equipment. The sign shall read, in print size no less than one-half (1/2) inch in size, **"GAS VENT DIRECTLY BELOW. KEEP CLEAR OF ALL OBSTRUCTIONS"**.
4. **INSPECTION.** The state or local gas inspector of the side wall horizontally vented gas fueled equipment shall not approve the installation unless, upon inspection, the inspector observes carbon monoxide detectors and signage installed in accordance with the provisions of 248 CMR 5.08(2)(a) 1 through 4.
 - (b) **EXEMPTIONS:** The following equipment is exempt from 248 CMR 5.08(2)(a)1 through 4:
 1. The equipment listed in Chapter 10 entitled "Equipment Not Required To Be Vented" in the most current edition of NFPA 54 as adopted by the Board; and
 2. Product Approved side wall horizontally vented gas fueled equipment installed in a room or structure separate from the dwelling, building or structure used in whole or in part for residential purposes.
 - (d) **MANUFACTURER REQUIREMENTS - GAS EQUIPMENT VENTING SYSTEM NOT PROVIDED.** When the manufacturer of a Product Approved side wall horizontally vented gas fueled equipment does not provide the parts for venting the flue gases, but identifies "special venting systems", the following requirements shall be satisfied by the manufacturer:
 1. The referenced "special venting system" instructions shall be included with the appliance or equipment installation instructions; and
 2. The "special venting systems" shall be Product Approved by the Board, and the instructions for that system shall include a parts list and detailed installation instruction.
 - (e) A copy of all installation instructions for all Product Approved side wall horizontally vented gas fueled equipment, all venting instructions, all parts lists for venting instructions, and/or all venting design instructions shall remain with the appliance or equipment at the completion of the installation.



Empire Comfort Systems Inc.
918 Freeburg Ave. Belleville, IL 62220

If you have a general question about our products, please e-mail us at
info@empirecomfort.com.

If you have a service or repair question, please contact your dealer.

www.empirecomfort.com